

National Aeronautics and  
Space Administration

---

NOT MEASUREMENT  
SENSITIVE

NASA-HDBK-4001  
FEBRUARY 17, 1998

# **ELECTRICAL GROUNDING ARCHITECTURE FOR UNMANNED SPACECRAFT**

**NASA TECHNICAL HANDBOOK**



## FOREWORD

This handbook is approved for use by NASA Headquarters and all NASA Centers and is intended to provide a common framework for consistent practices across NASA programs.

This handbook was developed to describe electrical grounding design architecture options for unmanned spacecraft. This handbook is written for spacecraft system engineers, power engineers, and electromagnetic compatibility (EMC) engineers. Spacecraft grounding architecture is a system-level decision which must be established at the earliest point in spacecraft design. All other grounding design must be coordinated with and be consistent with the system-level architecture.

This handbook assumes that there is no one single “correct” design for spacecraft grounding architecture. There have been many successful satellite and spacecraft programs from NASA, using a variety of grounding architectures with different levels of complexity. However, some design principles learned over the years apply to all types of spacecraft development. This handbook summarizes those principles to help guide spacecraft grounding architecture design for NASA and others.

Requests for information, corrections, or additions to this handbook should be directed to the Reliability Engineering Office, Mail Code 301-456, the Jet Propulsion Laboratory, 4800 Oak Grove Dr., Pasadena, CA 91109. Requests for additional copies of this handbook should be sent to NASA Engineering Standards, EL01, MSFC, AL 35812 (telephone 205-544-2448).

Daniel R. Mulville  
Chief Engineer

This Page Left Blank Intentionally

TABLE OF CONTENTS

<u>PARAGRAPH</u>	<u>PAGE</u>
<u>FOREWORD</u> .....	i
<u>TABLE OF CONTENTS</u> .....	iii
<u>LIST OF FIGURES, TABLES, AND APPENDICES</u> .....	iv
1. <u>SCOPE</u> .....	1
1.1 Scope .....	1
1.2 Purpose .....	1
1.3 Applicability .....	1
1.4 Constraints .....	1
2. <u>APPLICABLE DOCUMENTS</u> .....	2
2.1 General.....	2
2.2 Government documents .....	2
2.2.1 Specifications, standards, and handbooks .....	2
2.3 Order of precedence .....	2
3. <u>ACRONYMS AND DEFINITIONS</u> .....	2
3.1 Acronyms used in this handbook.....	2
3.2 Introduction of Concepts .....	3
3.3 Types of Grounding Systems .....	6
3.4 Bonding of Structural Elements.....	8
3.5 General Comments: Floating Circuits and Test Verification. ....	8
4. <u>GROUNDING ARCHITECTURE REQUIREMENTS/SELECTION CRITERIA</u> ..	8
4.1 Size of Spacecraft .....	8
4.2 Specific Implementations.....	9
4.2.1 Main Power Distribution System: Single or Multiple Voltages.....	13
4.2.2 Ground Fault Isolation of the Main Power Bus .....	14
4.2.3 Power Sources .....	15
4.2.4 Power User Load Isolation From Power Distribution System.....	15
4.2.5 General Interface Circuits (Command, Signal, Data, etc.).....	16
4.2.6 Attitude Control Elements.....	16
4.2.7 RF Interfaces.....	16
4.2.8 Pyro Firing Unit.....	17
4.2.9 Other Special Items, including Cable Overshields.....	17
4.3 Interface Isolation Circuits .....	18
4.4 Grounding of Support Equipment.....	20
4.5 Heritage Spacecraft.....	20

## FIGURES

<u>FIGURE</u>		<u>PAGE</u>
1.	Model Spacecraft With Subsystems.....	4
2.	Drawing Nomenclature/Key.....	4
3.	DC Isolated Ground and Not Isolated Ground.....	5
4.	Single-Point "Star" Ground.....	6
5.	Multiple Point Ground.....	6
6.	Multiple, Single Reference Ground System.....	7
7.	Floating (Isolated) Grounds.....	7
8.	Daisy-Chain Ground System (Not Recommended).....	8
9.	Hardware Issues for Spacecraft Grounding Architecture.....	10

## TABLES

<u>TABLE</u>		<u>PAGE</u>
I.	Spacecraft Grounding Criteria Based on Spacecraft Size and Complexity.....	9
II.	Spacecraft Grounding Architecture Selection Issues and Recommendations.....	12
III.	Totally Isolated Circuits (Hard Isolation).....	18
IV.	Partially Isolated Interface Circuits (Soft Isolation).....	19
V.	System Grounding and Isolation Used in Various Spacecraft.....	21

## APPENDICES

<u>APPENDIX</u>		<u>PAGE</u>
A	Sample Ground Trees For Large Complex Spacecraft.....	22

## ELECTRICAL GROUNDING ARCHITECTURE FOR UNMANNED SPACECRAFT

### 1. SCOPE

1.1 Scope. This handbook describes spacecraft grounding architecture options at the system level. Implementation of good electrical grounding architecture is an important part of overall mission success for spacecraft. The primary objective of proper grounding architecture is to aid in the minimization of electromagnetic interference (EMI) and unwanted interaction between various spacecraft electronic components and/or subsystems. Success results in electromagnetic compatibility (EMC). This handbook emphasizes that spacecraft grounding architecture is a system design issue, and all hardware elements must comply with the architecture established by the overall system design. A further major emphasis is that grounding architecture must be established during the early conceptual design stages (before subsystem hardware decisions are made). The preliminary design review (PDR) time is too late.

1.2 Purpose. The purpose of this handbook is to provide a ready reference for spacecraft systems designers and others who need information about system grounding architecture design and rationale. The primary goal of this handbook is to show design choices that apply to a grounding system for a given size and mission of spacecraft and to provide a basis for understanding those choices and tradeoffs.

1.3 Applicability. This handbook recommends engineering practices for NASA programs and projects. It may be cited in contracts and program documents as a reference for guidance. Determining the suitability of this handbook and its provisions is the responsibility of program/project management and the performing organization. Individual provisions of this handbook may be tailored (i.e., modified or deleted) to meet specific program/project needs and constraints. The handbook is specifically intended for application to NASA unmanned spacecraft. Other spacecraft development efforts can benefit to the degree that they are similar in their mission.

1.4 Constraints. This handbook does not cover personnel safety (such as the National Electrical Code) or regulatory compliance (such as Federal Communications Commission regulations). No practice recommended in this Handbook is hazardous.

Grounding of structure (bonding of non-electrical elements) is not the subject of this handbook. There is a short bonding section (ref. 3.4) that refers to another appropriate document.

This is a system level description of grounding. Application to a specific design may require reference to guidelines for specific topics such as power systems or electromagnetic compatibility.

## 2. APPLICABLE DOCUMENTS

2.1 General. The documents cited in this handbook are listed in this section for reference. Full implementation of these guidelines may require direct use of the reference documents.

### 2.2 Government documents.

2.2.1 Specifications, standards, and handbooks. The following specifications, standards, and handbooks form a part of this handbook to the extent specified herein.

#### DEPARTMENT OF DEFENSE

MIL-B-5087	-	Bonding, Electrical, and Lightning Protection, for Aerospace Systems
MIL-STD-1553	-	Digital Time Division Command/Response Multiplex Data Bus
MIL-STD-1576	-	Electroexplosive Subsystem, Safety Requirements and Test Methods for Space Systems
MIL-STD-1773	-	Fiber Optics Mechanization of an Aircraft Internal Time Division Command/Response Multiplex Data Bus

2.3 Order of precedence. Not applicable to this handbook.

## 3. ACRONYMS AND DEFINITIONS

### 3.1 Acronyms used in this handbook.

A	ampere
ac	alternating current (greater than zero frequency)
ACS	attitude control subsystem (sometimes called Attitude Determination and Control System - ADCS)
COTS	commercial off-the-shelf
C&DH	command and data handling (sometimes called Command and Data Management System - CDMS)
dc	direct current (zero frequency)
EED	Electro Explosive Device (squibs; pyrotechnic devices)
EMC	electromagnetic compatibility
EMI	electromagnetic interference
end-circuit	as used in this handbook, end-circuit refers the transmitting or receiving circuit that acts as an interface to cabling and another subsystem.
GSE	ground support equipment
H-field	magnetic field
I/F	interface
JPL	Jet Propulsion Laboratory



k $\Omega$	kilohm
kg	kilogram
M	million
m	meter
M $\Omega$	megohm
mA	milliampere
MHz	megahertz
MIL	military
N/A	not applicable
PDR	preliminary design review
pF	picofarad
PWR	power subsystem
pyro	pyrotechnic
RF	radio frequency
RFS	radio frequency subsystem
RIU	remote interface unit (an external add-on element of circuitry to meet interface requirements without modifying existing hardware designs)
RTG	radioisotope thermoelectric generator
Rtn	return
S/C	spacecraft
SPG	single-point ground
STD	standard
str	structure
VME	Versa Module Euro card (bus standard)
V	volt
W	watt
<	less than
>	greater than
$\mu$ F (uF)	microfarad
$\lambda$	wavelength

3.2 Introduction of Concepts. This section introduces and defines concepts and nomenclature used in this handbook. The ground referencing system must not only be a direct current (dc) voltage reference but an alternating current (ac) zero-potential system for deliberate high-frequency signals and incidental high-frequency noise, such as noise caused by dc-dc switching power converters that are common in modern spacecraft. Simple illustrations are used here; Section 4 provides greater details.

As an example of the system level of coverage discussed in this handbook, see Figure 1. Figure 1 shows a sample spacecraft, with radio frequency subsystem (RFS), attitude control subsystem (ACS), and a power subsystem (PWR). Other subsystems are omitted from this figure for clarity. A "spacecraft" consists of the flight hardware (as contrasted with the nonflight support equipment). Many of the following drawings show subsystems only, with the spacecraft frame (chassis) assumed but not shown.

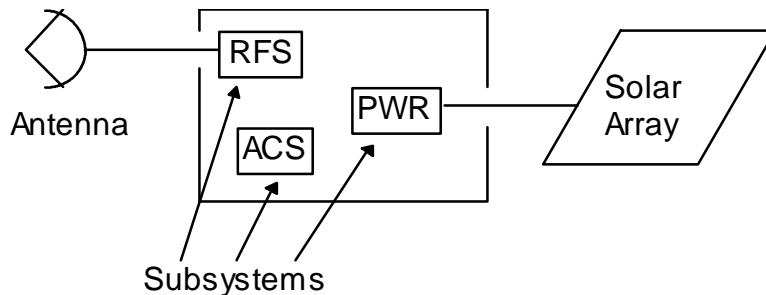

FIGURE 1. Model Spacecraft With Subsystems

Although the emphasis is at the spacecraft or system level, if a single assembly or experiment is relatively large, it also could be considered as a system, and the grounding architecture considerations discussed here could be applied to it separately. Figure 2 shows some drawing nomenclatures used in this handbook.

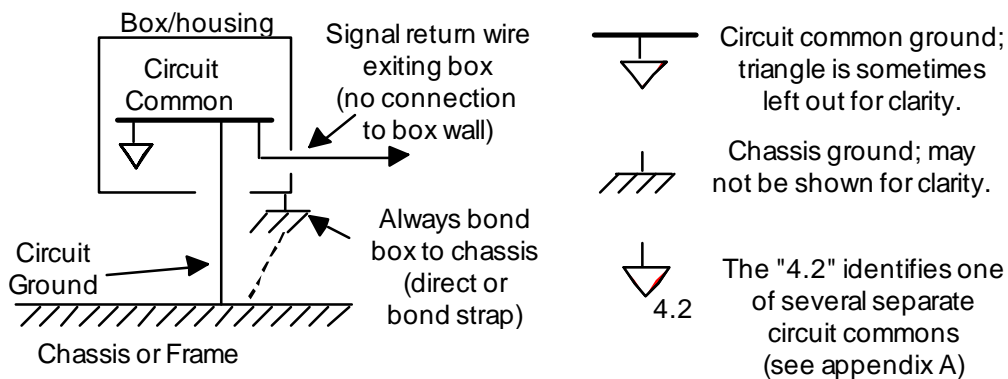

FIGURE 2. Drawing Nomenclature/Key

Isolation of grounds is an important concept. Isolation means the net dc and ac extraneous or noise current is substantially reduced (the best isolation is no noise current whatsoever) in the isolated interface. If there is a dc signal ground connection between two assemblies and they each also have a separate wire ground to chassis, their signal interfaces are not isolated from each other. Figure 3 illustrates both isolation of grounds between two subsystems and also lack of isolation (permitting a ground loop). Signal return current can flow both in the return wire as well as through the chassis ground connections. An example of a dc isolated interface between assemblies is a transformer used to transmit ac power; there is no dc path between the assemblies.

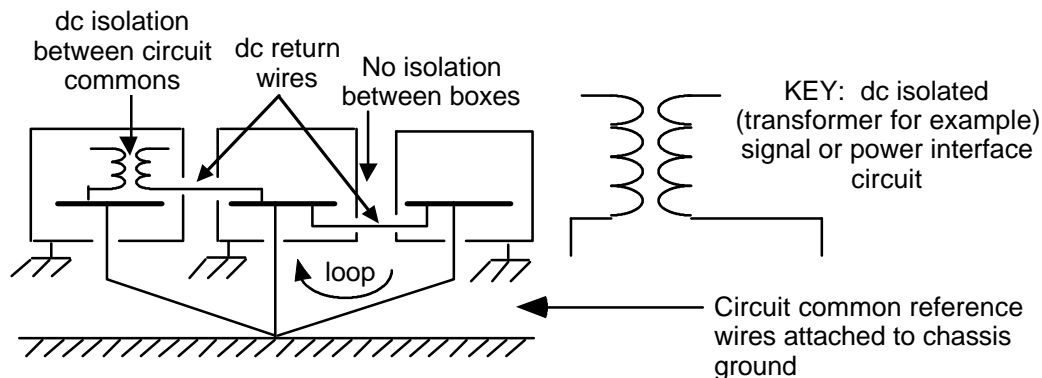

FIGURE 3. DC Isolated Ground and Not Isolated Ground

Ground loops can be troublesome because they can both radiate and receive magnetic field noise. AC magnetic field noise can couple into and disturb other circuits. DC magnetic fields can disturb onboard dc magnetometers. The key to minimizing the effects of ground loops is to minimize the enclosed area around which current flows. Ideally, every power and signal interface circuit will have 100 percent of its current (over all frequencies) return on a dedicated return wire in close proximity to the outgoing power or signal wire.

The lines (wires) connecting the subsystem common to the chassis actually consist of a series resistance, a series inductance, and various capacitances to nearby objects, all of which affect the performance of the grounding architecture. If the currents or voltages in question are at higher ac frequencies (generally above 1 megahertz (1 MHz)), the inductance and capacitance may become significant parameters that affect the quality of the ground. This handbook does not address high frequency issues. For a good ground at higher frequencies, shorter wire lengths are better (a ground wire should be shorter than one twentieth of a wavelength).

Isolation methods are discussed in more detail in 4.3.

3.3 Types of Grounding Systems. The two principle types of grounding systems are the single-point ground (SPG) and the multiple-point ground (see Figures 4 and 5). There are numerous other similar terms used for these concepts. Note that sometimes the actual implementation may negate the intended effects. The single-point ground in Figure 4 may be interpreted literally to mean that all circuit commons are grounded by means of wiring to one single point on the chassis. Note the isolation of grounds (circuit commons) between assemblies, so that there is one and only one dc ground reference path for each assembly. This is sometimes called a “star” ground because all ground wires branch out from the central point of the star. Inductances of long wires and higher frequencies can negate the adequacy of the ground to the degree that the assembly may no longer have a zero potential reference with respect to chassis. See Figure 6 for a better implementation.

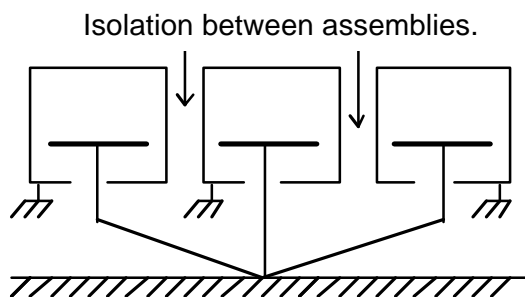

FIGURE 4. Single-Point “Star” Ground

Figure 5 shows a multiple point (multi-point or multi-path) ground arrangement. Note that each circuit common is grounded directly to the chassis and also grounded indirectly to the chassis via the connections to the other assemblies. This is typical for radio frequency (RF) subsystems but should not be used for video or other signals containing low frequencies (less than roughly 1 MHz).

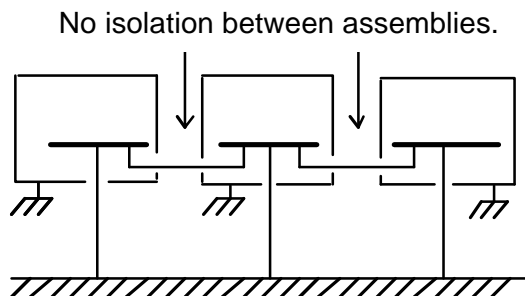

FIGURE 5. Multiple-Point Ground

Figure 6 shows a better chassis reference ground system. Each assembly has one and only one path to the chassis (the zero voltage reference), and there are no deliberate structure currents. Compared to the star SPG of figure 4, each ground reference wire is short, providing minimum ac impedance between each circuit common and chassis. The important points are that each electronic item has one and only one path to chassis, and there is no deliberate chassis current. Also, all subsystems have a common dc voltage reference potential (the interconnected structure). This grounding architecture is typical for a modern spacecraft (S/C)

that pays special attention to grounding architecture, including isolation of interfaces and minimized structure currents.

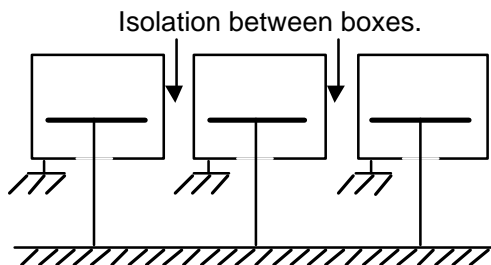

FIGURE 6. Multiple, Single Reference Ground System

Figure 7 shows a floating (isolated) ground system (generally not desirable). While systems are usually ground referenced in some manner, there is no theoretical reason why an assembly's circuit common needs to be chassis referenced. However, practical considerations dictate that at least a static bleed resistor be present, even if isolation from chassis ground is designed into the subsystem/system (circuit commons isolated from chassis are vulnerable to noise pickup through parasitic paths). [ Note: a bleed resistor is a resistor attached to chassis that is large enough that it has no practical electrical effect on the circuit, but it permits any stray charge to "bleed" to ground, thus providing a "soft" ground reference.] Note that an isolated ground system is not in compliance with man-rated systems or the National Electrical Code.

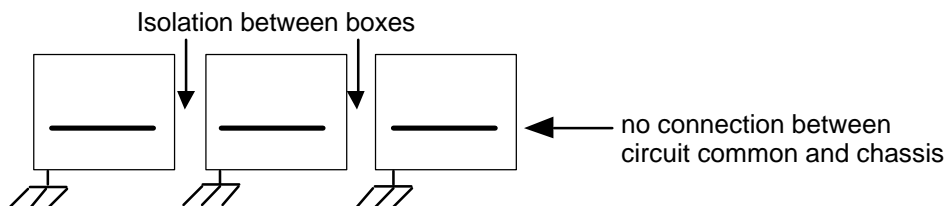

FIGURE 7. Floating (Isolated) Grounds

Figure 8 shows a daisy-chained ground system. This is a poor practice in general, and it is shown only to emphasize that it should not be done. Shared return wires cause common mode voltage differences (circuits "talk" to each other through common mode impedance coupling). It may be tolerable if it is done within the confines of a specific system component such as an attitude control subsystem, and the subsystem provides the box-to-box wiring. If it is permitted for separately built assemblies that are later integrated together, unpredictable behavior may occur.

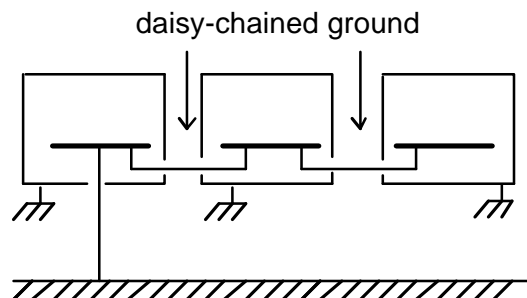

FIGURE 8. Daisy-Chained Ground System (Not Recommended)

3.4 Bonding of Structural Elements. Bonding refers to low-impedance connections of structural and other conductive elements of the spacecraft that do not deliberately carry electrical currents. Bonding does not mean the same as grounding, but the two words are often used in similar context. Good bonding provides a uniform near-zero volt reference plane at all frequencies for the electrical system returns. MIL-B-5087B has been the normal bonding standard and is a recommended reference. Bonding of all chassis elements is essential to provide a common voltage reference point for all of the various grounded subsystems.

3.5 General Comments: Floating Circuits and Test Verification. Floating electronic elements should be avoided. To prevent floating elements (and wiring which may float when switch contacts are open), a static bleed resistor (perhaps 5 megohm) to the chassis can be hard wired into the circuitry for any circuit that might float when not mated to other units or which might be isolated for any reason at any time.

It is desirable to make all explicit requirements testable. To verify isolation of interface circuits, it is a simple matter to use a common ohmmeter, probing into the appropriate connector pin (with a breakout box or other pin-saver device as a means of access to the pin). Capacitance to the chassis can be measured with a capacitance meter at the same time. It may be important to specify the test voltage as part of the requirements; selection of the proper test voltage is not a part of this handbook.

One possible design feature for verifying that there is a single path to ground is to have the subsystem's signal-point ground reference routed out through a connector pin, then returned into the subsystem and to chassis via a jumper in the mating connector of this design. This design feature permits verification of both the isolation and the grounding. A disadvantage of having the grounding implemented in the mating cabling is that it adds complexity to the cabling design. An alternative testable design, also adding complexity, is to have the ground brought out through an insulated stud in the wall of the box, then brought back to an adjacent grounded stud.

#### 4. GROUNDING ARCHITECTURE REQUIREMENTS/SELECTION CRITERIA

System designers should understand the following grounding design choices and have reasons for their selected grounding architecture.

4.1 Size of Spacecraft. Size is an appropriate criterion for choice of grounding schemes for both technical and practical reasons. Technically, smaller spacecraft have smaller distances between hardware; shorter distances translate into smaller stray voltage

between hardware; shorter distances translate into smaller stray voltage differentials. Practically, providing electrical isolation at all interfaces costs resources (design time, parts, volume, mass, etc.) that smaller programs may not be able to afford.

The best grounding system is a single reference ground per Figure 6, or its equivalent. This is not always practical or necessary. The best determinant of the grounding method required is the size and complexity of the spacecraft, as shown in Table I. When using table I, note that the grounding criteria depends on a majority of the listed parameters. It is acceptable if a few parameters don't match. However, performance requirements, such as the EMC needs of science instruments on an otherwise small spacecraft may dictate implementation of large/complex spacecraft grounding methods.

After deciding on spacecraft size per table I (large, medium, or small), refer to section 4.2 for applicable details of recommended appropriate spacecraft grounding architecture.

TABLE I. Spacecraft Grounding Criteria Based on Spacecraft Size and Complexity. †

Parameter	Large/complex	Medium	Small/simple
Size/diameter	>3 meter	1-3 m	<1 m
Mass	>2000 kilograms (kg)	200-2000 kg	<200 kg
Mission Lifetime	>3 years (36 months)	18 months - 3 years	<18 months
Power	>800 watts (W)	200-800 W	<200 W
Cost	>\$1000 million (M)	\$100M-1000M	<\$100M
EMC needs	Very sensitive to noise; quiet science platform*	Medium	Insensitive (motors, etc.)*
Reliability classification	Highest	Medium	Demonstration missions
Examples	Voyager, Galileo, Hubble, Cassini, EOS, AXAF	TOPEX/Poseidon, GOES, SIR-C, Magellan	Clementine, VME bus; New Millennium, "one-box" S/C

\* Low field dc magnetometers, low-frequency E-field and H-field sensors, and/or extremely low signal levels, would dictate using large spacecraft design principles.

† Some of the example spacecraft use grounding schemes other than those recommended in this handbook, and have not had grounding problems.

4.2 Specific Implementations. Grounding can be separated into the following nine functional areas (see Figure 9, sheets 1 and 2):

- (1) Main power conditioning/distribution system: single or multiple voltages
- (2) Power bus fault isolation resistance (impedance)
- (3) Power sources (battery, etc.)
- (4) Power user (load) interfaces with power bus
- (5) Command, signal, and data interfaces
- (6) Attitude control subsystem (often needs special treatment)
- (7) Radio frequency (RF) interfaces
- (8) Pyrotechnic (pyro) firing unit
- (9) Other and Special cases

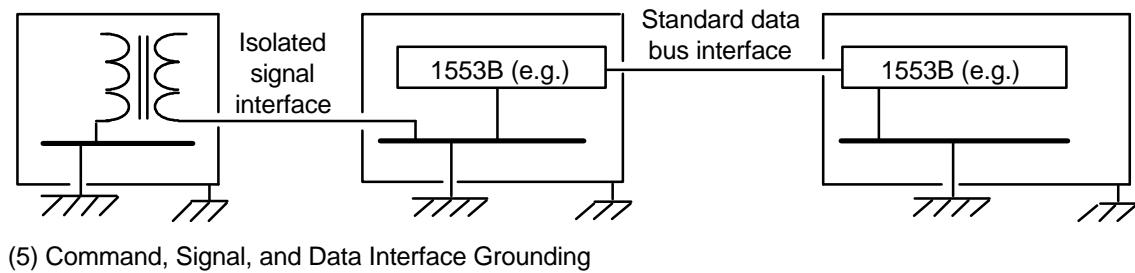
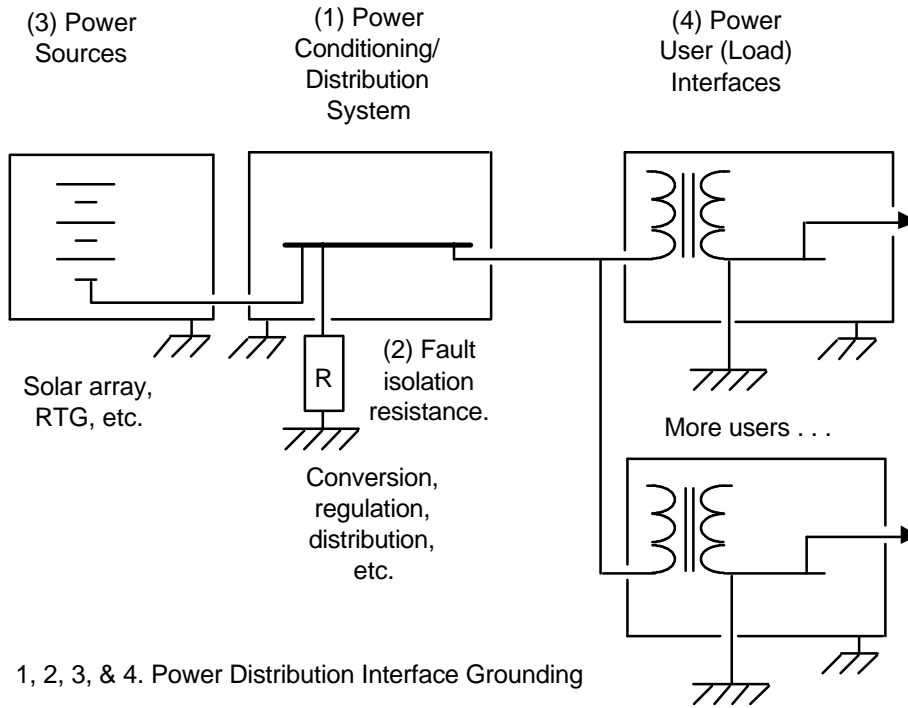
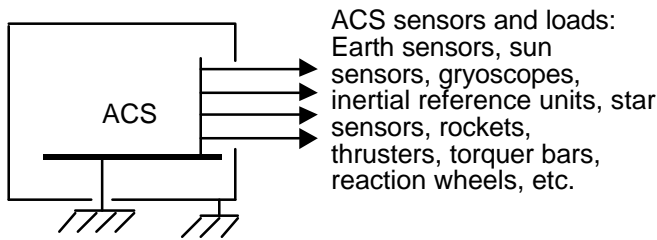

FIGURE 9. Hardware Issues for Spacecraft Grounding Architecture (Sheet 1 of 2)





ACS sensors and loads:  
Earth sensors, sun  
sensors, gyroscopes,  
inertial reference units, star  
sensors, rockets,  
thrusters, torquer bars,  
reaction wheels, etc.

ACS elements are located on the same ground tree because ACS elements usually share a single power supply and it is difficult to isolate the many internal interfaces.

(6) Attitude Control Subsystem Interfaces

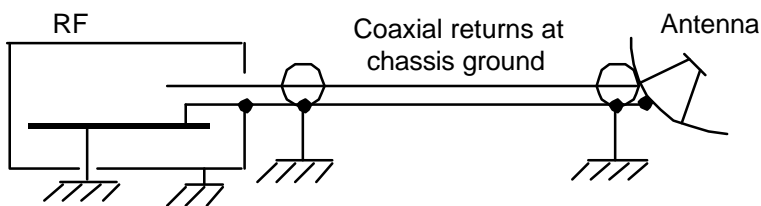

RF circuit common is multipoint grounded for performance reasons. There is no way to isolate high frequencies from chassis ground.

(7) Radio Frequency Interfaces

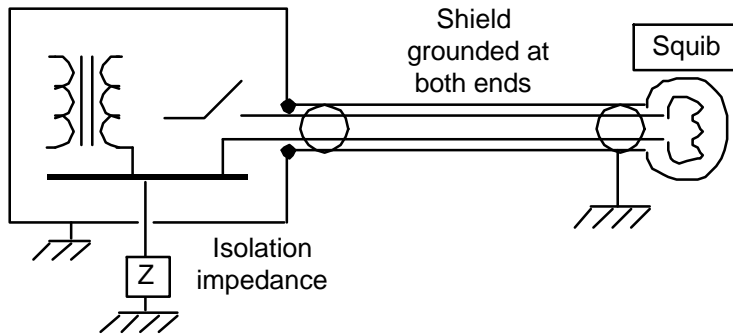

Shield grounded at both ends to extend Faraday Cage over EED wiring.

(8) Pyrotechnic Firing Unit

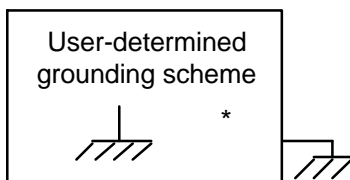

Instruments with low-level signals, boom mounted, science instruments, electric propulsion, etc.

\* requires approval by EMC Engineer

(9) Other Special Cases, Needing Special Interface Grounding Treatment

FIGURE 9. Hardware Issues for Spacecraft Grounding Architecture (Sheet 2 of 2)

Table II summarizes the grounding selection issues and recommendations as keyed to the three spacecraft sizes (degree of grounding control). Paragraphs 4.2.1 through 4.2.9 provide further discussion of these nine grounding issues.

TABLE II. Spacecraft Grounding Architecture Selection Issues and Recommendations

<b>Hardware/ Interface Issue</b>	<b>Large/Complex Spacecraft <sup>(1)</sup></b>	<b>Medium Spacecraft</b>	<b>Small/Simple Spacecraft</b>	<b>Comments</b>
1. Power distribution system; single or multiple voltages to user loads	Single dc voltage to user loads	Single dc voltage to user loads	Permit multiple voltages to user loads	Prefer using single dc voltage to loads; small can use multiple; for example VME bus/backplane
2. Ground fault isolation of main power bus	Isolate primary power return from chassis <sup>(2)</sup>	Isolate primary power return from chassis	Permit non-isolated; permit chassis currents if EMC allows	Prefer fault isolation and low chassis currents
3. Power sources (solar array, battery, RTG) grounding to chassis	Isolate the elements; provide ground referencing at power electronics assembly	Isolated	Isolated	Usually easily isolated
4. Power users (subsystem/load); isolation from power distribution sys.	Power input (primary to secondary) isolated at user to load interface	Power input (primary to secondary) isolated at user/load	Isolation is preferred	Commercial off-the-shelf dc-dc converters often provide power isolation as-bought
5. General interface signal circuits (command, signal, and data, etc.) grounding/isolation	All signal interfaces between subsystems are isolated RS-422, 1553 bus, etc., are permitted	<sup>(3)</sup>	Direct, non-isolated subsystem interfaces permitted	
6. Attitude control elements, including propulsion	All interfaces isolated; referenced at central ACS electronics assembly.	<sup>(3)</sup>	In small S/C, ACS and C&DH system might be integrated	Attitude control needs special attention because of the many remote sensor elements

TABLE II. Spacecraft Grounding Architecture Selection Issues and Recommendations  
(Continued)

Hardware / Interface	Large/Complex Spacecraft <sup>(1)</sup>	Medium Spacecraft	Small/Simple Spacecraft	Comments
7. RF interfaces	Multi-path	Multi-path	Multi-path	RF signals need multipoint. (Non-RF I/F's treated per issue 5)
8. Pyro firing unit	Isolated firing electronics	Direct energy transfer	Direct energy transfer	Isolation for pyro ground fault concerns
9. Other special (boom mounted, science instruments, slip rings, electric propulsion, plasma experiments)	Generally provide ground strap down dielectric boom to give good chassis reference; route separately from signal cabling			So unique that it is hard to generalize what to do; must be handled on an individual basis

NOTES:

- 1 Large/Complex Spacecraft entries list the best/most desirable (but usually most costly) design practices.
- 2 The high side (+) short to chassis will not have large currents if the return (-) is isolated.
- 3 If the cell is blank, it means there is no specific recommendation. This is frequently the case for the Medium Spacecraft, where the choice may be toward the isolated or the multipoint design at the system designer's discretion.

4.2.1 Main Power Distribution System: Single or Multiple Voltages. The first consideration of the spacecraft grounding architecture is whether the main power distribution system delivers a single voltage which is subsequently modified by user loads' power converters, or whether the central power distribution system provides all the voltages needed by user loads. The single voltage system (often 28 volts) is more common on larger spacecraft.

A single voltage simplifies maintenance of a single reference ground system. Each user load is responsible for both the internal dc-dc power conversion and the isolation from primary bus to the secondary voltages used by the subsystem. This is the preferred system and is recommended.

The multiple voltage distribution system is more easily used in a small spacecraft environment; for example, when all electronic subsystems are located on boards in a single box such as a Versa Module Euro card (VME) backplane configuration. A corollary of this system is that secondary signal and power interfaces within the box may not be isolated from each other. With short distances and compact electronics, this may not cause electromagnetic interference problems. They can still be dc isolated from the chassis for fault isolation (4.2.3).

**4.2.2 Ground Fault Isolation of the Main Power Bus.** A very important decision is whether to ground the power system return wire to the chassis, which is easy to do. Such a ground is generally implemented directly to the chassis near the power conditioning/distribution system (with a short wire/strap). This reduces common mode noise at the user interfaces. It also reduces the magnitude of noise radiated from the power system wiring, especially on spacecraft that have highly sensitive experiments measuring fields and charged particles.

However, having the return wire grounded to the chassis permits a single unfused fault from the positive wire to the chassis that could destroy the mission. This has been the cause of several mission failures (table V). For that reason, it is strongly recommended that the power return be isolated from the chassis by some modest impedance, high enough to limit current in case of a fault but low enough to provide a stable reference (see the following paragraph). If the power system is isolated from the chassis, all items attached to the power bus must also be isolated from the chassis (paragraphs 4.2.3 and 4.2.4). Note that if this design (soft grounding) is implemented, there is the possibility of greater power bus common mode noise, and power user loads should have greater common mode noise immunity. An alternate approach would be to bypass the isolation impedance with a capacitor. Such extra requirements are considered to be a tolerable side effect when balanced against the greater advantage of tolerance to high-side shorts to the chassis.

If the power system is hard grounded to chassis, it is necessary to ensure that unfused power shorts to chassis are not credible failure modes by design (e.g., double insulation), inspection, and/or test.

Isolation of the power return from the chassis only needs to be a moderate resistance. For instance, isolation of 2 kilohm ( $k\Omega$ ) limits chassis currents to milliamps for a 28 volt system ( $28V/2 k\Omega$  equals 14 milliamperes, and worst-case power loss of 0.39 W). This keeps the power return close to chassis potential but prevents loss of mission.

A more complex solution is to have a direct path to the chassis SPG through an appropriately sized fuse or circuit breaker that is paralleled by a current-limiting resistor as previously described. This permits solid power system grounding for common mode noise reduction, prevents total failure in the event of a power system high-side short to the chassis, and still has a soft reference to chassis after such a failure. For this to work, all main power bus loads must have been designed to be dc isolated from the chassis.

The Cassini spacecraft (an example of of a large/complex spacecraft grounding implementation) uses a balanced floating ground system for primary (30 V) power (Appendix A). Both high (+) and return (-) wires are referenced to chassis through 2 k $\Omega$  resistor.

4.2.3 Power Sources. Solar arrays, batteries, and other power sources are normally electrically dc isolated from the chassis as manufactured. In order to maintain a single ground reference system, it is convenient to leave them isolated. Even in a multipoint grounded spacecraft, there is little need to deliberately ground the power sources.

One special situation is radioisotope thermoelectric generators (RTG's). Their nuclear radiation may degrade the insulating materials inside the generator (over many years), leading to shorts and/or leakages within the generator case. For this reason, designers of power systems with RTG's should consider power wiring isolation (no hard grounding of the return wires to the chassis in the spacecraft) to reduce the effects of RTG case leakages. Alternatively, isolation of the RTG case from the spacecraft chassis can prevent this concern.

Another special situation is space plasma considerations. Solar arrays can leak power through the conductivity of space, due to the ions and electrons in space plasmas. The higher the solar array voltage, the more the leakage possibility. At higher voltages, (as low as 200 V on a positive grounded array and as low as 100 V on a negative grounded array) arcing may occur. If high-voltage solar arrays are planned in some low- to geosynchronous orbits, floating the array may become very important (that is, designers should not chassis reference either of the power leads from the solar array).

4.2.4 Power User Load Isolation From Power Distribution System. If power returns are not isolated at the user load interfaces (verify by ohmmeter measurement from power input leads to chassis), there can be ground currents in the spacecraft chassis. Power wiring dc isolation is usually specified to be 1 megohm (M $\Omega$ ). Sometimes an ac isolation limit, such as no more than 0.1 microfarad ( $\mu$ F) capacitance (from low side to chassis or from high side to chassis), is also specified to control higher frequency current loops. Note that isolation really means limiting current flow. The recommended 1 M $\Omega$  would then mean that less than 28  $\mu$ A dc to the chassis is permitted per subsystem (28 V bus assumed).

When commercial-off-the-shelf (COTS) isolated dc-dc power converters are made part of the original subsystem design (interfacing with the spacecraft dc power bus), isolation is a relatively low-cost requirement. For this reason, it is recommended that most spacecraft be designed so that all user loads are isolated from the main dc power bus.

Isolation should be verified by measurement of all user loads.

4.2.5 General Interface Circuits (Command, Signal, Data, etc.). If the systems designer has chosen to have a spacecraft grounding system that is totally isolated across all interfaces, then all signal circuits (command, signal, and data, etc.) must be isolated. Note that only one end of an interface (sending or receiving) needs to be isolated.

A recommended requirement for isolation of signal interfaces is 1 M $\Omega$  and 400 picofarad (pF). That is, a measurement from either a signal wire or its return to chassis should measure greater than 1 M $\Omega$ , and there should be less than 400 pF of capacitance to the chassis. For signals that share a single return wire, the requirement for the return may be eased to a per circuit basis (for two circuits with a shared return, the impedance from return wire to the chassis should be greater than 0.5 M $\Omega$ , and the capacitance from return wire to the chassis should be less than 800 pF, etc.).

Standard differential interface driver receiver pairs (e.g., the unidirectional RS-422 or the bi-directional MIL-STD-1553 bus circuits) generally are designed so that there are zero-to-low structural ground currents. For that reason, such circuits are permitted per this handbook when interface isolation is specified. Note, however, that the interface may violate the isolation needs when the circuits are unpowered. There may be non-intuitive/undocumented paths in the driver or receiver chip that permit ground currents to flow when the chip is unpowered. Also, these kinds of circuits have less immunity to common mode noise than isolation devices such as transformers or optical isolators.

If a high degree of isolation is required between subsystems that are already designed and/or built, an add-on assembly (sometimes called a remote interface unit, or RIU), can be used to accept the subsystem's signals and dc isolate individual circuits to the interfacing subsystem.

4.2.6 Attitude Control Elements. The attitude control subsystem presents practical difficulties for an optimal grounding system implementation. This subsystem often consists of one or more remote sensing units, one or more remote hardware elements for adjusting spacecraft orientation, and a central control assembly. If these hardware elements are bought as COTS equipment from various vendors, their signal and power interfaces may not comply with the selected spacecraft grounding architecture.

The solutions to these unique dilemmas cannot be resolved in this handbook. Isolation may be achieved by specifying isolation from the vendor, by designing an external isolating interface unit (RIU), or by designing isolating interfaces into the central control assembly. Another solution is to use COTS hardware and accept any resulting chassis ground currents. In this case, one should quantify any effects on EMC or reliability.

4.2.7 RF Interfaces. RF signals usually have frequencies so high that the  $\lambda/20$  criterion would dictate that all hardware items should be within a few centimeters or less of the single point ground. (For a wire to be a real ground, it should be shorter than 1/20th of a wavelength at the frequency of concern.) Because this is a practical impossibility, most RF signals employ the multipoint ground scheme. If dc isolation is essential in an RF system, the RF grounding can be achieved by numerous capacitors.

Note that the non-RF interface circuits within RF subsystems must be isolated like general interface signal circuits in order to maintain an isolated grounding architecture. Therefore, the analog and digital systems inside RF units should be physically and electrically separated from the RF sections as much as possible (with RF chokes for example), starting with the initial design.

**4.2.8 Pyro Firing Unit.** Pyro firing units may need special treatment if the most conservative design is used. The greatest threat to be dealt with is the phenomenon called pyro ground-fault currents. Chassis currents as great as 20 ampere (A) may occur during pyro firing events. The ground fault current is caused by a short circuit from the positive pin to the chassis through the conductive hot plasma of the powder charge, and it continues like the arc of an arc welder. This may occur in 25 percent of the firings. In a direct-energy transfer system (pyros switched directly from the main battery bus) that is not isolated by a deliberate turn-off switch, the ground fault current could continue indefinitely when fired by a battery. The ground fault current could cause magnetic field noise coupling into nearby sensitive circuits or a near total power loss. This mechanism is compatible with several spacecraft anomalies and failures listed in table V.

To prevent pyro ground-fault currents, the pyro firing unit must be electrically isolated from the chassis. One way to isolate (if the main power bus is not already isolated) is a power converter that isolates the pyro firing unit from both the dc power bus and from the chassis as shown in figure 9 (panel 8). Other solutions are a separate isolated battery, a capacitor discharge subsystem resistively isolated from the main power bus on high side and return, or use of an isolation relay.

Isolation of the pyro firing circuit is not necessary if it can be ensured that all critical interface circuits are so well-designed that they are not sensitive to electrical noise, if the circuitry is software-tolerant to transient signals, and if some power loss can be accepted.

MIL-STD-1576 is a commonly required reference, defining many aspects of pyro design, including special shielding and grounding requirements for range safety.

**4.2.9 Other Special Items, Including Cable Overshields.** For various reasons, there may be needs for special grounding requirements. These include but are not limited to boom-mounted hardware, science instruments, slip rings, electric propulsion subsystems, and plasma experiments. Grounding needs depend on the individual sensitivity and performance requirements of each system, and the local grounding design must be tailored for each of them.

Shield grounding is an important consideration. For intersubsystem cables with an overshield for EMC purposes, the shield should be grounded at both ends at the entry point to the subsystem or assembly. A 360 degree EMC backshell connector is preferred in this application.

In all these special circumstances, systems require a well-thought-out spacecraft electrical and electronic grounding scheme at the outset of the program. Working out each system element's special needs will be easier if the other parts of the spacecraft grounding architecture have been designed in a clear and consistent manner.

4.3 Interface Isolation Circuits. In order to maintain the integrity of a ground referencing scheme, electrical isolation must be maintained across all interfaces (power, signal, command, and data). Isolation means that little or no current flows in the structure path. Table III shows examples of totally isolated circuits, and Table IV shows circuits that provide a lesser degree of isolation. Of course, totally isolated interface circuits are preferred, but the Table IV circuits are better than no isolation at all.

TABLE III. Totally Isolated Circuits (Hard Isolation)

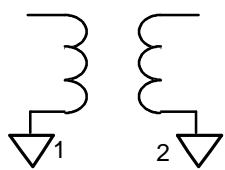
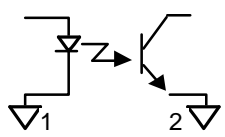
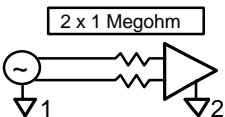
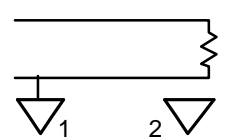
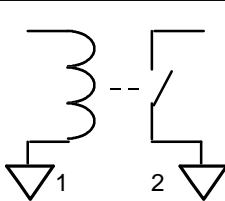
TYPE	SCHEMATIC	ADVANTAGE	DISADVANTAGE	COMMENTS
Transformer		Isolation, transmits differential signals	Large, heavy, costly, limited frequency range; interwinding capacitance	Examples: 1553 data bus, clock interfaces
Optical coupling		Wide freq range, small, rejects common mode noise	Power consumption, linearity, radiation hardness	MIL-STD-1773 for example
Isolated analog op-amp		Easy to implement. Power OFF isolated	Low bandwidth extra part count	
Remotely referenced (e.g., temperature transducer)		Simple	Electrical insulators are not good thermal conductors	Commonly used
Relay (coils to contacts)		Excellent dc and ac isolation	Shorter life, low-frequency response, large, binary only; high stray capacitance in power switching relays	



Note that in each of these devices, the input and output are isolated from each other by a high dc impedance; usually 1 MΩ or more. AC isolation generally deteriorates at frequencies above 1 MHz. Because of stray capacitances that do not show on the schematic, this is particularly true with the operational amplifier as its common mode rejection ratio parameter decreases with increasing frequency.

When using isolated end-circuits in high-frequency applications, it is important to be aware of parasitic reactive paths, such as interwinding capacitance in a transformer or distributed packaging capacitance as in remotely referenced circuitry.

TABLE IV. Partially Isolated Interface Circuits (Soft Isolation)

TYPE	SCHEMATIC	ADVANTAGE	DISADVANTAGE	COMMENTS
Normal analog op amp; differential amplifier		Easy to implement	Not isolated when op-amp is off; common mode noise rejection may be a problem	
Common mode choke		DC continuity, rejects common mode noise	Permits low-frequency ground loops	
Balanced circuit differential amplifier		Noise couples equally to both wires. CMR rejects noise	AC isolation limited. DC isolation lost with power OFF. Common mode rejection decreases with frequency.	Not generally recommended
Line-driver/receivers		Established interface standard	Possible lack of common mode noise immunity; possible lack of isolation if power is off	Generally an acceptable interface design solution
Transmission lines	Properly terminated circuits	Minimize noise coupling	Not really isolated	Use with multi-point grounding

4.4 Grounding of Support Equipment. Support equipment used for testing the spacecraft should be constructed to maintain the grounding architecture for the spacecraft. In general, all interfaces between flight hardware and support equipment should be isolated.

4.5 Heritage Spacecraft. Spacecraft programs studied to establish these guidelines include those listed in table V.

TABLE V. System Grounding and Isolation Used in Various Spacecraft

Spacecraft	Power System Type/Voltage	Primary Power Ground Type	Primary Power Isolation to Structure/Resistance and Capacitance	Ground Type, Signal	Ground Type, Pyro	In-flight Grounding/ Isolation Problems
Mariner-2 (1962)	Solar arrays/batt. 30 V dc; 50 V rms, 2.4 kHz ac	Rtn to Structure	N/A	Single ground reference with isolated I/F's	Switched from battery	Short to Str, one solar array
Viking'75 Orbiter (1975)	Solar arrays/batt. 50 V ac; 30 V dc	Isolated from structure	ac 47 k-ohm to str, each line; dc 3k-ohm paralleled with 0.01 uF on return to structure	Single ground reference with isolated I/F's	Isol. 5k ohm and 0.1 uF to Str.	Inverter failed at Lander release pyro event
Voyager (1977)	RTG 30 V dc; 50 V rms, 2.4 kHz ac	Balanced to structure	ac 47 k ohm and dc 10 k ohm symmetrically isolated and 0.1 uF dc return to structure	Single ground reference with isolated I/F's	Isol. 5k ohm and 1 uF to Str.	False telemetry readings at pyro fire: cause: 1 uF
Seasat (1978)	Solar arrays and battery	Isolated from structure	?	SPG each assy; I/F's not isolated	?	Slip ring short hi to low may be fail cause at 6 months
Magellan (1989)	Solar arrays/batt. 28 V dc; 50 V rms, 2.4 kHz ac	Balanced to structure	ac 47 k ohm and dc 2 k ohm symmetrically isolated & 0.1uF dc return to structure	Single ground reference with isolated I/F's	Isol. 5k ohm and 0.1 uF to Str.	Anomaly after SRM casing release pyro event
Galileo (1989)	RTG 30 V dc; 50 V rms, 2.4 kHz ac	Balanced to structure	ac 47 k ohm and dc 2 k ohm symmetrically isolated & 0.1uF dc return to structure	Single ground reference with isolated I/Fs	Isol. 5k ohm and 0.1 uF to Str.	Slip ring leak, pwr to chassis (minor and acceptable)
Hubble (1990)	Solar arrays and battery / 28 V dc	SPG Rtn to structure	True star ground, with very long wires (Note: very poor ac ground if no local capacitive bypass))	Multipoint; str. currents for signals	N/A (No pyro)	Old solar array blanket short exhibited str. Current.
Mars Observer (1992)	Solar arrays and battery / 28 V dc/10 V dc	Rtn to structure with 2 SPG's	N/A	Multipoint; str currents for signals	Rtn to Str	100% loss; cause unknown; during pyro event
TOPEX (1992)	Solar arrays and battery / 28 V dc	Rtn to structure	N/A	Single gnd ref, w/ isolated I/F's	Switched from battery	None
NOAA-13 (1993)	Solar panels and battery	Rtn to structure	N/A	Multipoint; str. currents for signals	Rtn to Str.	Hi-side short to Str 1 mo after launch. 100% loss
Cassini	RTG / 30 V dc	Balanced to structure	2 k ohm each, high side and return to structure; 0.1 uF Rtn to Str	Single ground reference with isolated I/Fs	Isol. 5k ohm dc and ac	Sch.1997 launch. See appendix A

NOTES: Rtn: return; Str: structure; some cells may be left empty due to lack of applicability ("N/A") or lack of knowledge ("?")

APPENDIX A  
 SAMPLE GROUND TREES FOR LARGE COMPLEX SPACECRAFT (PAGE 1 OF 2)

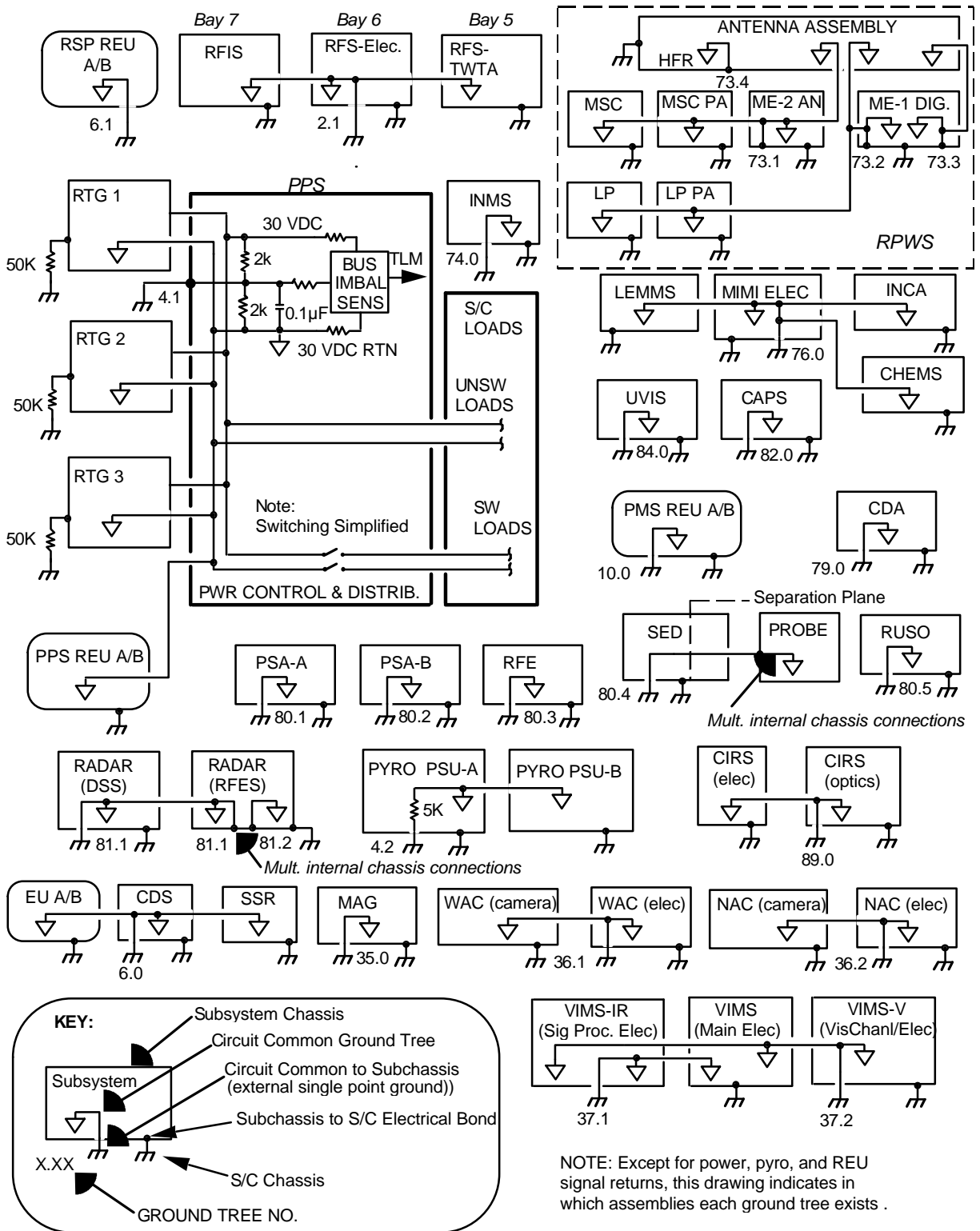

CASSINI GROUND TREES, Page 1 of 2

APPENDIX A  
 SAMPLE GROUND TREES FOR LARGE COMPLEX SPACECRAFT (PAGE 2 OF 2)

Bay 1

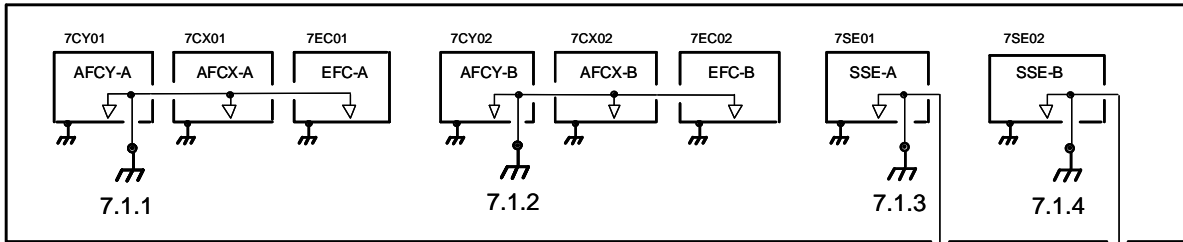

HGA

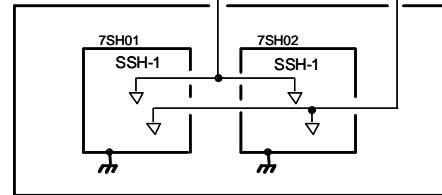

NOTE: Except for power, pyro, and REU signal returns, this drawing indicates in which assemblies each ground tree exists .

Bay 10

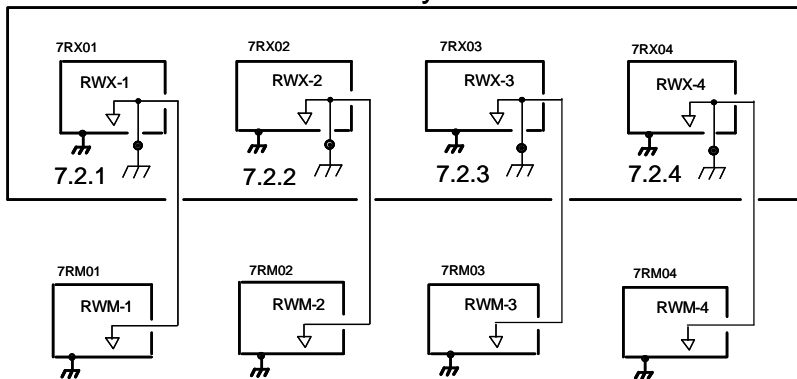

Bay 12

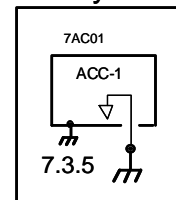

Bay B

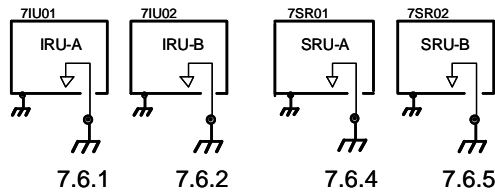
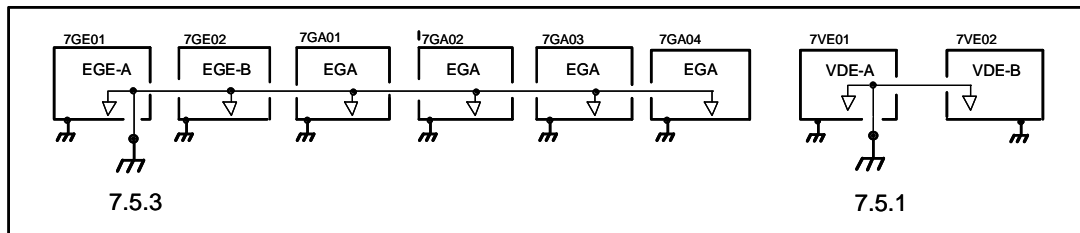

ACS Ground Trees