

IRN NO:	ISS PAYLOAD OFFICE IRN/PIRN/EXCEPTION FORM	PAGE 1 OF 30
		DATE PREPARED: 10/17/03

Doc. No., Rev. & Title: SSP 57000, Revision G Pressurized Payloads Interface Requirements Document	PIRN NO: 57000-NA-0301
---	----------------------------------

(P)IRN TITLE:
Payload Label Updates and Reductions

ORIGINATOR: Name: Rich Ellenberger/Rose Lindsey/Janet Kavandi Agency: NASA/Habitability & Human Factors Phone: 281-483-5238 FAX: 281-244-5773	PIRN Type: <i>Check one</i> <input checked="" type="checkbox"/> Standard PIRN <input type="checkbox"/> Exception	<i>For Payload Office Use Only</i> <input type="checkbox"/> Exceedance <input type="checkbox"/> Deviation <input type="checkbox"/> Waiver
---	--	--

Utilization Change Engineer: Name: Rich Ellenberger Agency: NASA IPLAT Phone: 281-483-5238 FAX: 314-777-2866	SSCN/CR	RELATED PIRN No.:
--	---------	-------------------

Agency Tracking No.: 57000-0225	SYSTEM/ELEMENT AFFECTED & STAGE EFFECTIVITY:
--	--

REASON FOR CHANGE: (INCLUDE APPLICABLE ICAP NUMBER)
This PIRN is a follow-up to the Lean 6 Sigma activity regarding Labels-OpNom. IPLAT, ODF, PODF, and Crew Office have completed a series of meetings to make all of our standards consistent. The result of that activity is this PIRN, which will make the label requirements consistent with SSP 50253 (ODF Standards) and SSP 50254 (OpNom standards). Some requirements were deleted. This PIRN will apply to newly designed payloads. Payloads that already have had an IPLAT initial label evaluation, or IPLAT approval will be grandfathered.

PARAGRAPHS, FIGURES, TABLES AFFECTED (For PIRN use only)

<u>Page</u>	<u>Paragraph(s)</u>	<u>Figures(s)</u>	<u>Table(s)</u>
	All Appendix C		

AFFECTED INTERFACING PARTIES						
	SIGNATURE & ORGANIZATION	DATE	SIGNATURE & ORGANIZATION	DATE	SIGNATURE & ORGANIZATION	DATE
C O N C U R	OZ3		SSBRP		MELFI	
	Boeing PEI		EXPRESS Sustaining		Cryo	
	S&MA		SPD		JAXA CR/LSG	
	IPLAT (Originator)		FCF		ESA	
	Crew		MSAD		JAXA JEM EI	
	HRF		BTF			

THE INFORMATION CONTAINED IN THE "PRESSURIZED PAYLOAD INTERFACE REQUIREMENTS DOCUMENT" IS INTERFACE REQUIREMENT DATA, WHICH IS CONTROLLED BY THE EXPORT ADMINISTRATION REGULATIONS (EAR) (15 CFR PARAT 730 et.seq.) AND CLASSIFIED AS EAR99 UNDER THE EAR. RE-EXPORT OR RE-TRANSMISSION OF SUCH DATA IN VIOLATION OF THE EAR OR OTHER EXPORT CONTROL LAWS AND REGULATIONS IS PROHIBITED.

APPENDIX A ABBREVIATIONS AND ACRONYMS

Add:

DDPF	Decal Design & Production Facility
GFE	Government Furnished Equipment
IMS	Inventory Management System
IP	International Partner
IPLAT	ISS Payload Label Approval Team
LCD	Liquid Crystal Display
LED	Light Emitting Diode
ODF	Operations Data File
OpNom	Operations Nomenclature
PD	Payload Developer
PDL	Payload Data Library
SI	Standard International
USPODFCB	United States Payload Operations Data File Control Board

From:

SSP 57000 Rev G Appendix C

To: (following pages)

APPENDIX C INSTRUCTIONS FOR LABELS AND DECALS

TABLE OF CONTENTS

C.1	INTRODUCTION.....	C-x
C.2	ISS PAYLOAD LABEL APPROVAL PROCESS.....	C-x
C.3	IPLAT APPROVAL INSTRUCTIONS.....	C-x
C.3.1	GROUND ASSEMBLY AND HANDLING.....	C-x
C.3.2	FUNCTION CONSIDERATIONS.....	C-x
C.3.3	PAYLOAD ORIENTATION.....	C-x
C.3.4	LABELING DESIGN.....	C-x
C.3.4.1	LABELING STANDARDIZATION.....	C-x
C.3.4.2	READABILITY.....	C-x
C.3.4.3	LABEL PLACEMENT.....	C-x
C.3.4.4	EQUIPMENT LABELING.....	C-x
C.3.4.4.1	EQUIPMENT IDENTIFICATION.....	C-x
C.3.4.4.2	EQUIPMENT CODING.....	C-x
C.3.4.4.2.1	CABLE AND HOSE LABELING.....	C-x
C.3.4.4.2.2	COLOR CODING.....	C-x
C.3.4.4.2.3	LOCATION AND ORIENTATION CODING.....	C-x
C.3.4.5	OPERATING INSTRUCTION LABELS.....	C-x
C.3.4.6	STOWAGE CONTAINER LABELING.....	C-x
C.3.4.7	GROUPED EQUIPMENT ITEMS.....	C-x
C.3.4.8	CAUTION AND WARNING LABELS.....	C-x
C.3.4.9	ALPHANUMERIC.....	C-x
C.3.4.9.1	FONT STYLE.....	C-x
C.3.4.9.2	PUNCTUATION.....	C-x
C.3.4.9.3	SPECIAL CHARACTER.....	C-x
C.3.4.9.4	LINE SPACING.....	C-x
C.3.4.10	IMS BARCODES.....	C-x
C.3.5	SCALE MARKING.....	C-x

TABLES

C.3.4.1.F-1	CHARACTER HEIGHT – 710 MM (28 IN) VIEWING DISTANCE....	C-x
-------------	--	-----

FIGURES

C.1-1	IPLAT PAYLOAD LABEL APPROVAL PROCESS.....	C-x
C.3.4.1.D-1	HARDWARE ID LABELS.....	C-x
C.3.4.3-1	RACK LABEL PLACEMENT.....	C-x
C.3.4.3-2	CONTROL PANEL LABELING.....	C-x
C.3.4.3-3	MISCELLANEOUS LABEL PLACEMENT EXAMPLES.....	C-x
C.3.4.4.2.1-1	CABLE AND HOSE LABELING.....	C-x
C.3.4.6-1	STANDARD PAYLOAD STOWAGE LABELS.....	C-x
C.3.4.7-1	GROUPING LABEL EXAMPLES.....	C-x
C.3.4.8-1	CAUTION AND WARNING LABEL EXAMPLES.....	C-x

C.1 INTRODUCTION

The ISS Payload Label Approval Team (IPLAT) reviews and approves labels for *all payload equipment that the crew will interface with during nominal operations, planned maintenance, and contingency operations*. IPLAT reviews labels against the instructions contained herein.

- Labels reviewed by IPLAT **include**, but are not limited to:
 - Rack/subrack front panel type hardware
 - All experiment equipment, loose or mounted other than in rack/subrack formation
 - All equipment cables, fluid lines, hoses, etc.
 - All equipment controls, switches, ports, LEDs, stowage containers, etc
- Items IPLAT does not review:
 - Items which the crew will not interface with (e.g. internal circuit boards, etc.)
 - Labels contained within software displays, procedures, cue cards. These are handled by the U.S. Payload Operations Data File Control Board (USPODFCB) or appropriate Operations Data File (ODF) control board.

Appendix C provides instructions for the approval of payload labels. The development of labels is a joint process requiring the cooperative efforts of IPLAT and the payload developer (PD). The process for developing labels begins with the PD providing pre-released engineering drawings, and ends with the delivery of flight certified labels. The label approval process flow diagram is shown in Figure C.1–1.

To understand the priorities of the instructions, the following definitions need to be applied throughout Appendix C.

Statements with “ must” will be used for instructions that are required to be met for IPLAT to provide approval.

Statements with “should” will be used for instructions that are incorporated into the label unless adequate justification is provided to IPLAT to warrant exempting the label instruction.

The term “label” used throughout these instructions refers to any one of the following:

Silk-screened labels: Markings that are silk-screened, with ink, onto hardware.

Decals: Peel-off labels with adhesive backing that are applied onto hardware.

Ink-stamped labels: Markings, stamped with ink, onto the hardware.

Engraved or etched labels: Markings carved onto the hardware surface.

Placards: Cards that are inserted into pockets.

Any other method of applying markings onto hardware.

SSP 50005, International Space Station Flight Crew Integration Standard (NASA-STD-3000/T) was used as the basis for the payload labeling guidelines contained herein.

C.2 ISS PAYLOAD LABEL APPROVAL PROCESS

The PD is responsible for providing drawings with label location and content, and information sufficient to enable IPLAT to determine that the instructions herein are met. The PD must deliver drawings to the Payload Data Library (PDL), or other database accessible by IPLAT.

IPLAT is responsible for reviewing all payload labels, providing guidance to the PD and granting approval based on the instructions herein. IPLAT is also responsible for performing a human engineering assessment of the labels and ensuring the labels are appropriate from a human engineering perspective, including commonality, and standardization. IPLAT reviews both U.S. and International Partner (IP) payload labels.

IPLAT reviews labels against the approved Operations Nomenclature (OpNom). IPLAT does not approve OpNom, procedures, and displays. OpNom is the operationally relevant term used to describe hardware. For U.S. payloads, OpNom is approved by the USPODFCB. For IP payloads, the appropriate ODF control board approves their OpNom. Approved OpNom can be found in the OpNom document, SSP 50254, and can also be found at <http://mod/jsc/nasa.gov/do3/ODF/OpNom/index.html>.

The process for obtaining approval of ISS payload labels is shown in Figure C.1-1. IPLAT performs two label evaluations, an initial and a final label evaluation. In preparation for the initial review, the preliminary OpNom review should be conducted first. The preliminary OpNom review consists of evaluating pre-released drawings (or material sufficient to represent the hardware's labeling) and the preliminary OpNom to determine if the OpNom is operationally relevant and usable for the hardware. After the preliminary OpNom review, the initial label evaluation is performed. This supports an integrated process prior to drawings being released and completion of hardware development. Upon receiving the drawings, or other materials, IPLAT has 10 working days to complete the initial label evaluation. IPLAT will return a checklist that documents any requirement violations, and suggested solutions. Once the initial label evaluation has been completed, all changes that potentially affect OpNom must be coordinated with all OpNom mandatory reviewers. The PD will update the label designs based on IPLAT's recommendations.

The final label evaluation can be completed in one of two ways: 1) via approval of released engineering drawings, or 2) review of digital images certified to be of the flight hardware with labels installed. With the first approach, labels should be ordered after IPLAT approval of the drawings via the JSC Form 732. With the second approach, labels must be ordered and then installed before pictures can be submitted to IPLAT for approval. This approach should be done in close coordination with IPLAT to ensure the correct labels get ordered and applied to the hardware in the correct locations. IPLAT has 10 working days to complete the final label evaluation. If the labels meet the requirements, IPLAT returns JSC Form 732, approved, to the PD. Form 732 is the PD's official verification that the labels meet the requirements, and should be included in the payload's verification record.

Labels must be installed and IPLAT approval completed before the payload's bench review.

The PTR Board is responsible for resolving issues and disagreements between the PD and IPLAT.

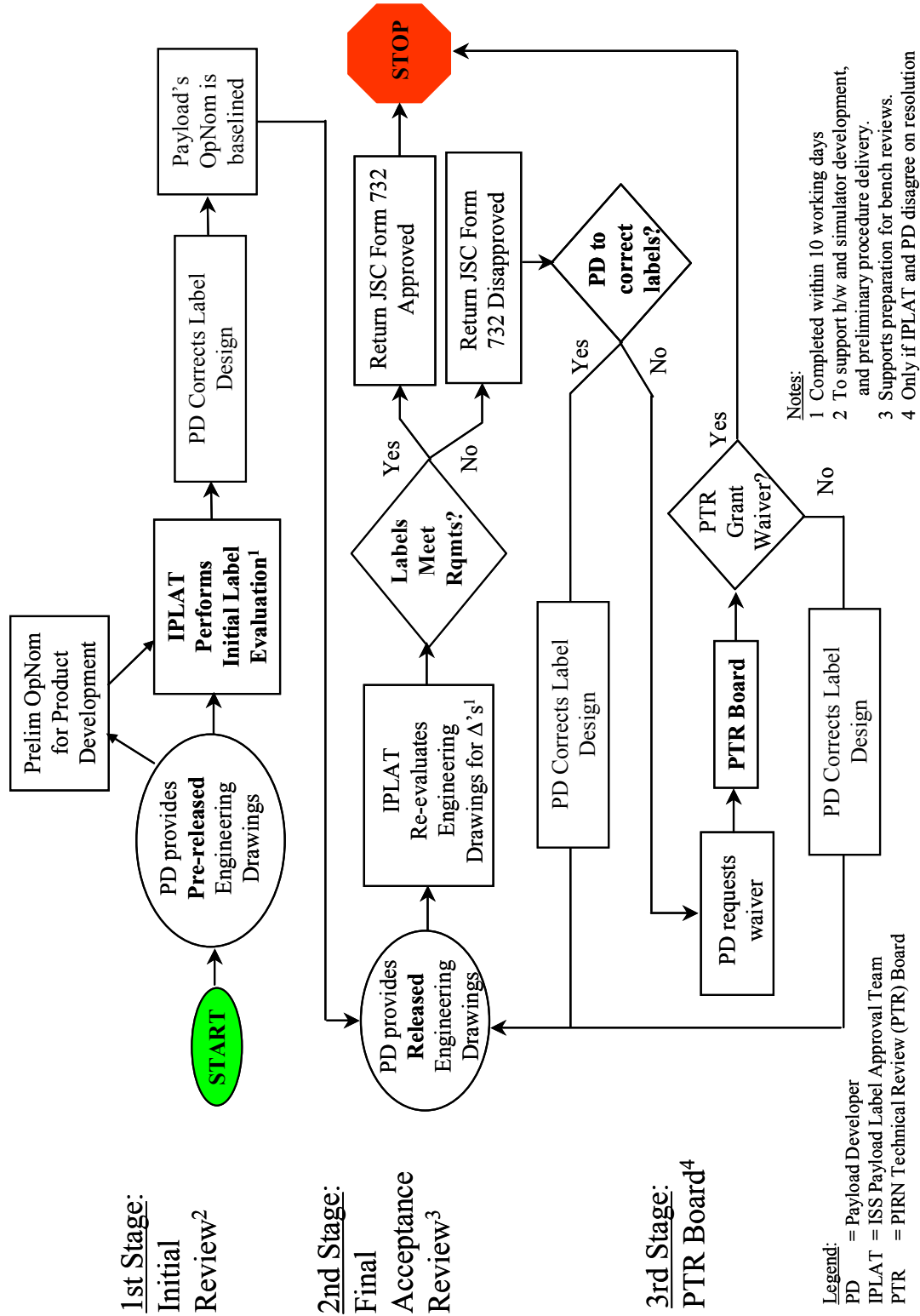

FIGURE C.1-1 IPLAT PAYLOAD LABEL APPROVAL PROCESS

C.3 IPLAT APPROVAL INSTRUCTIONS

IPLAT will use the following instructions in reviewing and providing the approval of payload labels.

The following definitions will be used throughout this section:

“Passive”, as it relates to payload hardware, is defined as hardware that cannot itself be powered, such as cables and hoses, consumables, etc.

“Active”, as it relates to payload hardware, is defined as hardware that can be powered and performs a specific payload function.

“Non-rack self-contained payloads” refers to a category of equipment that becomes powered, or active, but is not mounted on the front of a rack like a subrack payload.

“Loose Equipment” is defined as passive, unpowered equipment generally found in payload stowage (e.g. cables, consumables such as biocide wipes, science samples, tools, etc.)

C.3.1 GROUND ASSEMBLY AND HANDLING

Labels used for ground assembly and handling must not interfere with on-orbit crew interface labeling. Product marking for ground assembly and handling should be in accordance with MIL-STD-130, section 4, except paragraph 4.1.c.

C.3.2 FUNCTION CONSIDERATIONS

- A. Labels for crew interfaces must contain information regarding the operational interface (e.g. the purpose, the function, and/or the functional result of the use of equipment items) and comply with the approved OpNom. Engineering characteristics or nomenclature may be described as a secondary consideration.
- B. Instrument labels, for example, should be labeled in terms of what is being measured or controlled and use the approved OpNom. Calibration data may be included where applicable

C.3.3 PAYLOAD ORIENTATION

- A. Payload labeling, displays, and controls must have a consistent rack vertical orientation arrangement with the rack vertical axis origin at the bottom of the rack hinge point.
- B. Payload labels required for operations with the rack(s) rotated should be oriented with respect to required crew positions.

C.3.4 LABELING DESIGN

C.3.4.1 LABELING STANDARDIZATION

- A. Standard decals needed by the PD are available in JSC 27260, Decal Process Document and Catalog. Decals must either be obtained from the Decal Design & Production Facility (DDPF), or must be designed to be identical to them. Examples of labels found in the catalog are: Hardware ID labels, IMS barcodes, fire hole, toxicology, hazardous, caution and warning, rack power switch, fire indicators, cable/hose labels, etc. The DDPF is also available to PDs for fabricating labels not found in JSC 27260.
- B. Labeling must be standardized between and within systems.
- C. Payload labels must conform to the ODFCB approved OpNom, SSP 50254 and applicable partner annexes.
- D. Hardware ID label Text

Figure C.3.4.1.D-1 shows examples of payload hardware ID labels. The requirements for this label are as follows:

- (1) Each label must contain a horizontal line. A vertical line may be used for vertical space limitations.
- (2) ONLY the OpNom for the item to which the label will be applied must appear above the line or to the left of the line.
- (3) The payload's acronym (if applicable) must be spelled out on the main unit's hardware ID label. This should be placed directly below the line.
- (4) The part number and serial number (if applicable) must fall below the line, and below the spelled out payload name.
- (5) If the Inventory Management System (IMS) barcode is integrated with the hardware ID label, it must fall below the line, and be placed in the lower right hand corner of the label.
- (6) On control panel name labels, the OpNom must be above the line. The spelled out name, if needed, should be applied under the line.
- (7) No other text, other than that mentioned above, must appear on the hardware ID label.



a) Rack/subrack “main unit” name example



b) Rack/subrack “main unit” name example - vertical space limited

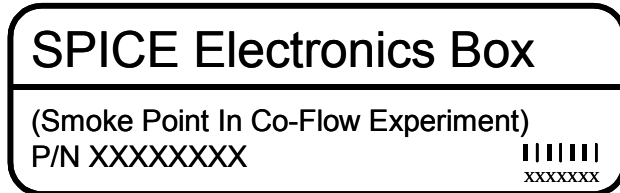

c) Example of “main unit” name for a “Non-rack self-contained payload”



d) Example of subordinate equipment name



e) Control Panel name example



f) Control Panel name example - vertical space limited

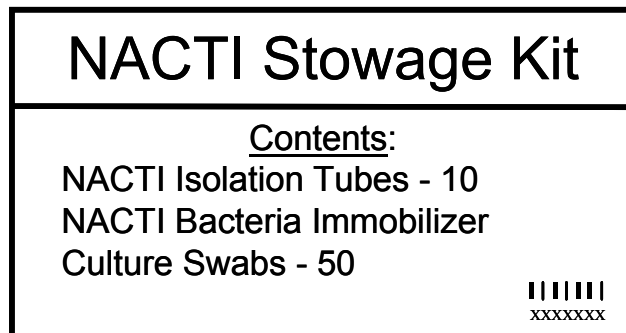

g) Stowage kit name/contents label

Figure C.3.4.1.D-1 HARDWARE ID LABELS

E. Casing:

- a) Controls labels on a control panel must be in UPPER case only.(e.g. switches and their positions, connector ports, LEDs, etc.). This includes abbreviations and acronyms.
- b) Hardware ID labels must be per the casing of the approved OpNom.
- c) Keypads – Non–COTS keypads on payloads should use title case letters.

F. Font Size

(1) Font Sizes of labels must be per Table C.3.4.1.F-1:

TABLE C.3.4.1.F-1 CHARACTER HEIGHT – 710 MM (28 IN) VIEWING DISTANCE	
MARKINGS	CHARACTER HEIGHT¹
Rack Name	48 Pt. Font (minimum) (0.48 in, or 12 mm)
Subrack Name	28-36 Pt. Font² (0.28-0.36 in, or 7-9 mm)
Non-rack Self Contained Payloads	12-36 Pt. Font² (0.12-0.36 in or 3-9 mm)
Loose Equipment	12 Pt. Font (minimum) (0.12 in or 3 mm)
Controls (e.g., switches, connector ports, etc.)	10-20 Pt. Font (0.10-0.20 in or 2.5-5 mm)
For critical markings, with position variable (e.g., numerals on counters and settable or moving scales)	20-31 Pt. Font (0.20-0.31 in.) (5-8 mm)
For critical markings, with position fixed (e.g., numerals on fixed scales, controls, and switch markings, or emergency instructions)	16-31 Pt. Font (0.16-0.31 in.) (4-8 mm)
Notes:	
1 These font sizes are for the OpNom appearing above the line on the hardware ID label. Text below the line on this label should be smaller.	
2 The name for the “main unit” should be larger than the names of subordinate equipment.	

- (2) Size Categories – Characters used in hierarchical labeling (e.g. rack name, subrack name, controls groupings, port names, etc.) should be graduated in size per Table C.3.5.10.4-1. There should be at least a 25 percent difference in the character height between each of these categories. Moved from C.3.5.10.4

C.3.4.2 READABILITY

A. Labels should be as concise and direct as possible.

B. Abbreviations must comply with SSP 50254.

C. Language

(1) Labels must be written in the English language.

(2) If dual languages are used, English must be used first and with lettering at least 25% larger than the secondary language.

D. Labels should be designed so as to minimize visual clutter.

E. Displays and Controls Title Selection - Physical Hardware

(1) When verbs are used to label physical hardware (buttons, switches, controls, etc.), the present tense should be used. For example: OPEN or CLOSE, BEGIN, or END, START or STOP, etc.

(2) Physical Hardware Linked to Software Displays – If physical hardware is linked to and/or represented by software displayed data or controls (i.e. LCD), the labels for the physical hardware and the software representation must match.

(3) Circuit Breakers

i) If the physical device in any way operates as a circuit breaker, the abbreviation “cb” must be used in the label. For example: POWER cb.

ii) Circuit breaker positions must be labeled OPEN and CLOSE, not ON and OFF or PUSH and PULL.

(4) Switches – Switches must be named according to their function.

(5) Push Buttons – Push buttons must be named according to their function. If necessary, use the word PRESS (not MASH, PUSH or DEPRESS) to instruct the crew how to operate it.

- F. Units of measure must be in Standard International (SI) units, unless otherwise required to match the hardware.

C.3.4.3 LABEL PLACEMENT

- A. All labels must be placed on the payload hardware in accordance to the label location drawings.
- B. Payloads Operated From Rack Front Panels – Labels for Payloads operated from the front panel of racks must be placed in accordance to Figure C.3.4.3-1.
 - (1) Rack hardware ID label – The rack hardware ID label must be placed in the upper left corner of the rack. If the IMS barcode is attached separately, it must be placed to the right of the hardware ID label.
 - (2) Subrack hardware ID label – The subrack hardware ID label must be placed in the upper left corner of the subrack. If the IMS barcode is attached separately, it must be placed to the right of the hardware ID label.
- C. Non-rack self-contained payloads – The hardware ID label must be placed in the upper left corner of the dominant face of the payload. If the IMS barcode is attached separately, it must be placed to the right of the hardware ID label.
- D. Loose Equipment
 - (1) The hardware ID label must be placed in the upper left corner of the dominant face of the payload. If the IMS barcode is attached separately, it must be placed to the right of the hardware ID label.
 - (2) Items that cannot accept a hardware ID label for form, fit, or functional reasons must have a hardware ID label for the item on the outside of its container.
- E. Control Panel Labels
 - (1) Control panels must have a hardware ID label with the approved OpNom.
 - (2) Positions - Labels must be centered above connectors, switches, LEDs, displays, controls, etc. Labels may be placed in other locations when they cannot dimensionally fit in the required location, or if they would be obstructed by items like cables and hoses, or to preclude misassociation with adjacent items.
 - (3) Font Size – Labels for controls on a panel should be smaller than the name label for the panel, and should be between 10 and 20 point font per Table C.3.4.1.F-1. Labeling for different levels of controls should be graduated in size. For example, grouping label

titles should be larger than the labels for the controls within them. Similar levels of controls should be the same size. See Figure C.3.4.3-2 for examples.

F. Part Numbers and Serial Numbers

- (1) Part Numbers and Serial Numbers should be placed together for ease of identification. If they are included in the hardware ID label, they must be placed below the line.
- (2) If the Part Number and/or Serial Number are not included in the hardware ID label, and a separate Part Number/Serial Number label are necessary, the Part Number should be arranged to the left or above the Serial Number.
- (3) “P/N” and “S/N”, which are the standard OpNom representations for Part Number and Serial Number, respectively, must be used.

G. Orientation – All markings and labels must be oriented with respect to the local worksite plane so that they read from left to right. Vertical orientation, with letters arranged vertically if the text is short (e.g. DATA J3), or rotating the label 90 degrees when the text is long (e.g. PAYLOAD ELECTRONICS MODULE), is permissible when the marking or label does not fit in the required orientation.

H. Visibility –All labels must be placed on equipment so that they are visible when the equipment is used or accessed. Markings should be located such that they are perpendicular to the operator’s normal line of sight whenever feasible and should not be less than 45 degrees from the line of sight.

I. Overhead Panels – On overhead panels, markings and labeling must be oriented such that they appear upright when observed from local vertical.

J. Association Errors – The arrangement of markings on panels should protect against errors of association of one marking or set of markings with adjacent ones.

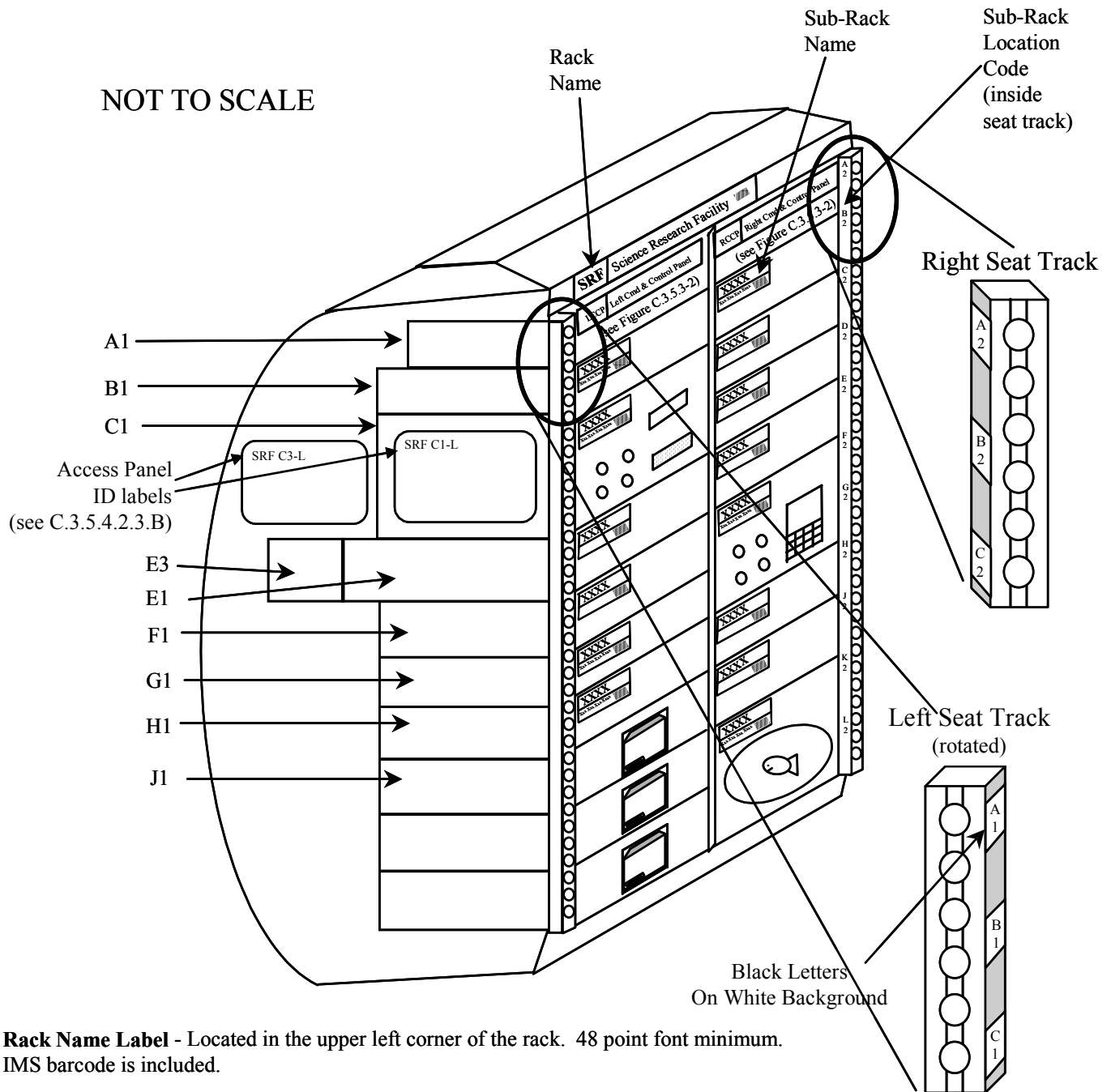

Rack Name Label - Located in the upper left corner of the rack. 48 point font minimum. IMS barcode is included.

Subrack Name Label - Located in the upper left corner of the subrack. Between 28-36 point font. IMS barcode is included.

Subrack Location Codes - Located on the inside of the seat track. Letters A thru N, excluding I (18 point font). Letter/number pairs must be placed at intervals equal to the individual rack's smallest drawer unit (e.g. 4 PU (7 inches) for U.S. payloads, different for IP racks).

FIGURE C.3.4.3-1 RACK LABEL PLACEMENT

NOT TO SCALE

This panel is at the "A1" position in Figure C.3.4.3-1:

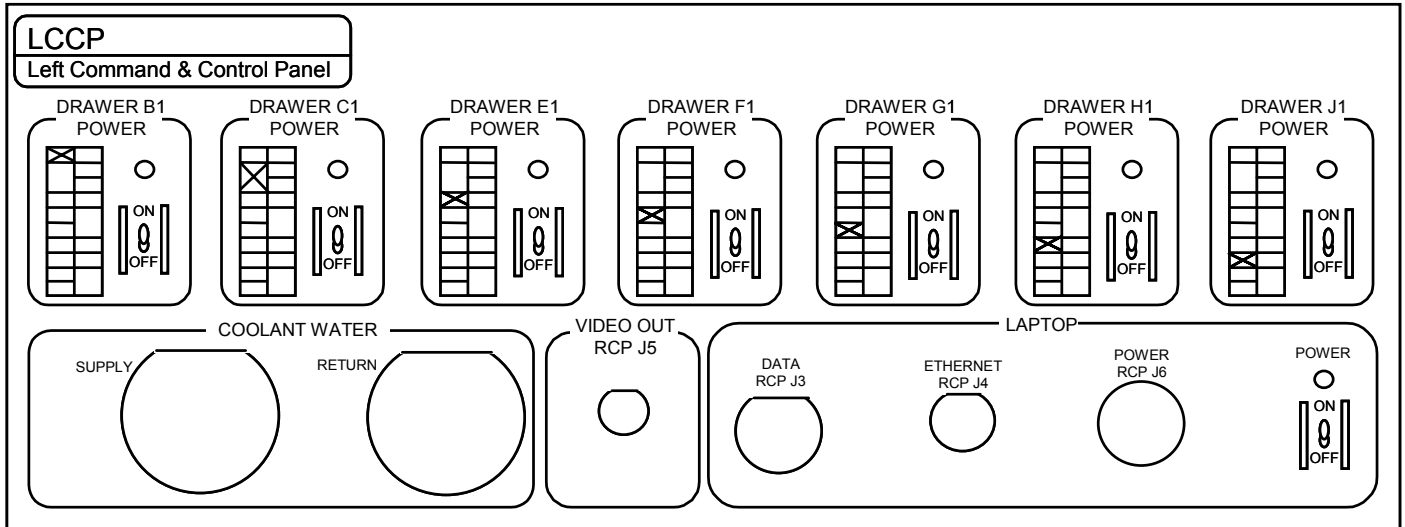

This panel is at the "A2" position in Figure C.3.4.3-1:

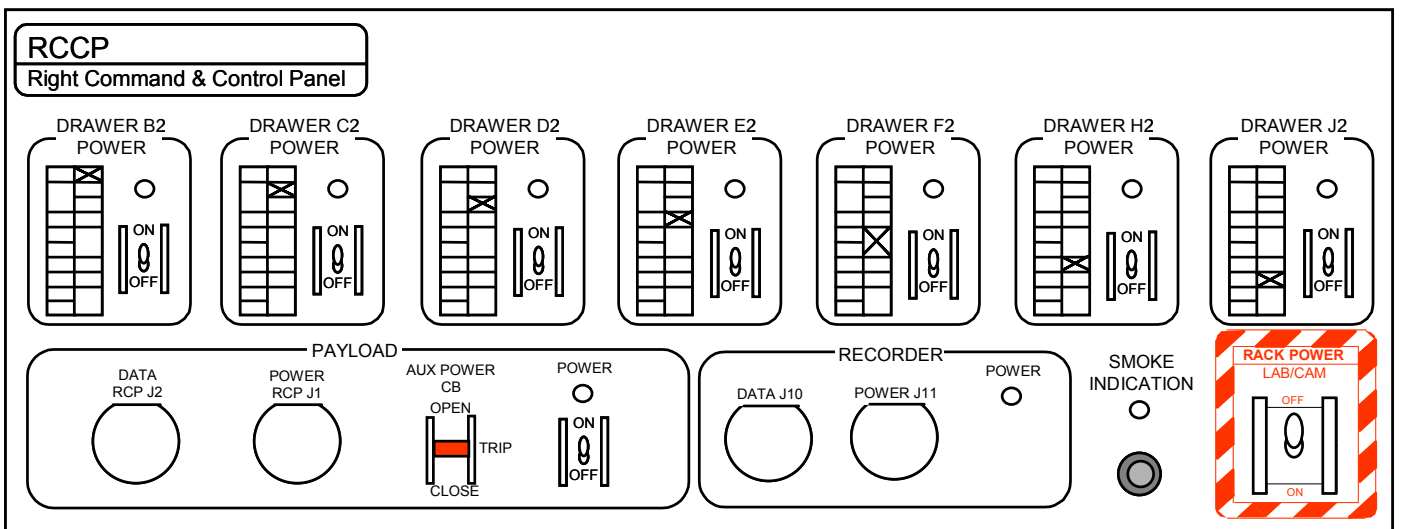

FIGURE C.3.4.3-2 CONTROL PANEL LABELING

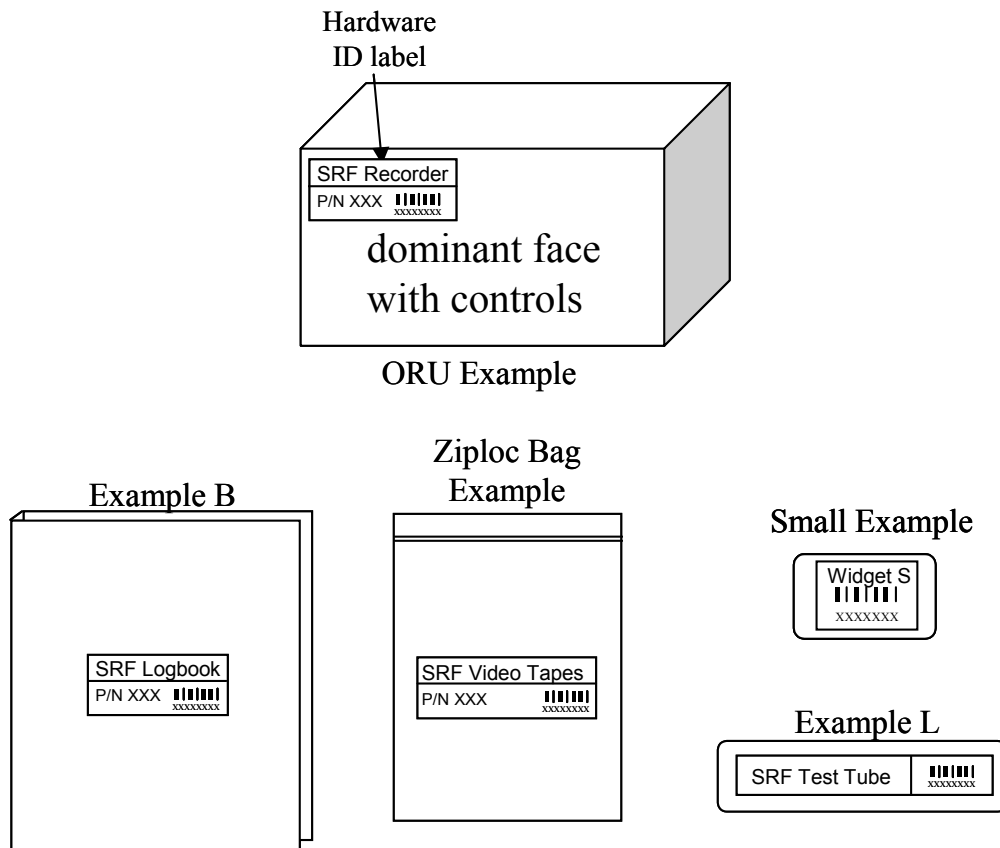

FIGURE C.3.4.3-3 MISCELLANEOUS LABEL PLACEMENT GUIDELINES

C.3.4.4 EQUIPMENT LABELING

C.3.4.4.1 EQUIPMENT IDENTIFICATION

- A. All items on a piece of hardware must be identified, including, but not limited to: displays, controls, switches, connectors, LEDs, containers, vents, etc., such that these items can be clearly referenced in crew procedures. Use of acronyms and abbreviations must be accordance with SSP 50254, OpNom document. Only those items whose use is obvious to the crew (e.g., food table, windows, etc.) are exempt from this instruction. The font size for these labels must be smaller than the main label naming the payload.
- B. Containers must be labeled to identify their contents using approved OpNom. (See Section C.3.5.7)
- C. Deleted
- D. Multi-quantity items

- (1) Multi-quantity items that are permanently installed into hardware (not loose) that require individual distinction but are not serialized must be individually numbered. Controls level items should be logically numbered/lettered left to right or top to bottom in descending order (e.g. “DRIVE A”, “DRIVE B”, “DRIVE C”).
 - (2) Serial Numbers – Multi-quantity items that are serialized should display the serial number as part of the identification.
 - (3) Move to C.3.5.7 (f)
- E. Logos – If organizational or commercial logo(s) are used, they must not be distracting to the crew while operating the payload. For front panels, the size of a logo should be smaller than the main name label.
- F. Trade Names – Trade names should not appear on labels (e.g. “Q-Tips”, “Scotch Tape”, “Kleenex”, “Duct Tape”, etc.). (taken from SSP 50005 9.5.3.12.H)

C.3.4.4.2 EQUIPMENT CODING

C.3.4.4.2.1 CABLE AND HOSE LABELING

- A. Crew Interface Cables and Hoses Definition – Electrical cables and hoses *which are interfaced with by the crew* for nominal operations (e.g. experiment operations), planned maintenance (e.g. ORU replacement), or are designed to have a crew interface in the event of a contingency situation, are considered “Crew Interface Cables and Hoses”, and are subject to the format requirements below.
- B. Crew Interface Cables and Hoses must have hardware ID labels, cable end labels, and any safety labels as deemed necessary. If one end of a cable or hose is permanently attached to a piece of hardware, that end does not require a cable end label, and it does not require an IMS barcode. The loose end that the crew interfaces with must have a cable end label to tell the crew where it mates. If the cable must be distinguished from other permanently attached cables on the same device, the cables must be labeled with the approved OpNom. If the cable or hose diameter is such that it can accept a sleeve/band style label, that is preferred. Flag style labels can be used if necessary. IPLAT can help the PD choose the appropriate style and size of the labels.
- (1) Electrical Cable End Plugs and Corresponding Electrical Connector Ports
 - a) The cable end plug must be designated with a “P” (e.g. P1), regardless of gender. Note: “P” should be used even for cable to cable connections.
 - b) The connector port on the hardware must be designated with a ”J”, regardless of gender, and should be preceded by a descriptive name (e.g. DATA J1 or POWER J2).

- c) The plug number and receptacle number for a mating pair should be identical (e.g. P1 mates with J1), except when not possible because a cable is generic.

(2) Cable and Hose Label General Characteristics

- a) Font Size - The font size of the text on these labels should be 12 point preferred, or 10 point minimum.
- b) Text/Background Color - The text should be black on a white background.
- c) Abbreviations must comply with SSP 50254.

(3) Cable and Hose Identifying Labels - Cables and hoses must contain a main identifying label with the information below. This label must be placed at the mid-length position of the cable/hose, *unless the cable or hose is 6 meters or greater, which would then require an identification label placed every 2 meters*. See Figure C.3.4.4.2.1-1 for examples.

- The OpNom of the cable/hose.
- For hoses: The flow direction should be indicated with an arrow below the OpNom if the hose ends are not interchangeable.
- The Part Number of the cable or hose (optional)
- The Serial Number of the cable or hose (optional)

(4) Cable and Hose IMS Barcodes – A cable/hose must have an IMS barcode. It must be placed to the right of the hardware ID label (if not using a standard hardware ID label with the IMS barcode included), at the mid-length position, as shown in Figure C.3.4.4.2.1-1.

(5) Cable and Hose End Labels - Labels at the terminal ends of cables/hoses must contain the information below in vertical order, center justified. See Figure C.3.4.4.2.1–1 for cable/hose label examples.

First Line: The name of this end of the cable/hose (e.g. for cables, P1). For a hose, if the end does not have a specific identifier, this line may be left off. If the hose end needs to have a unique identifier, do not use a “P” number (“P”s are reserved for cables).

Second Line: The word “To” followed by the OpNom of the piece of equipment to which this end of the cable/hose mates with. The text casing must match the OpNom.

If this end can interface to multiple connector ports (e.g. generic cables), this line may be left off.

Third Line: The exact name of the receptacle on the hardware that this end of the cable/hose mates with (e.g. DATA J1 or OXYGEN OUT). The text case must match the casing on the panel. If this end can interface to multiple connector ports (i.e. generic cables), this line may be left off. If the receptacle is on a piece of hardware not provided by the PD (e.g. GFE laptop), and the receptacle is not properly labeled, appropriate descriptive words must be used (e.g. SERIAL PORT).

- (6) Hose Hazard Labels – Hoses must have standard hazard class decals indicating the appropriate hazard level for the substance transported through the hose. This label must be placed to the right of the identifying label.

SCIENCE RESEARCH FACILITY (SRF)

NOT TO
SCALE

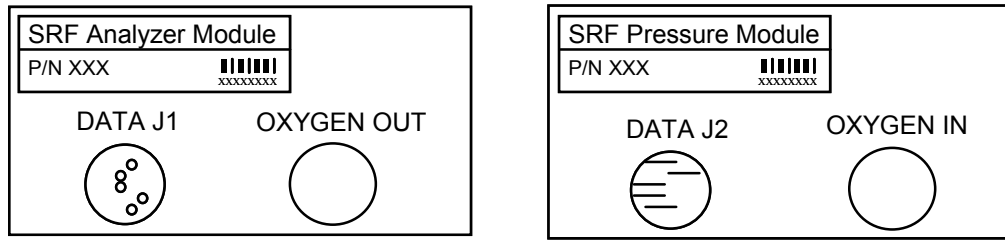

Electrical Cable Example

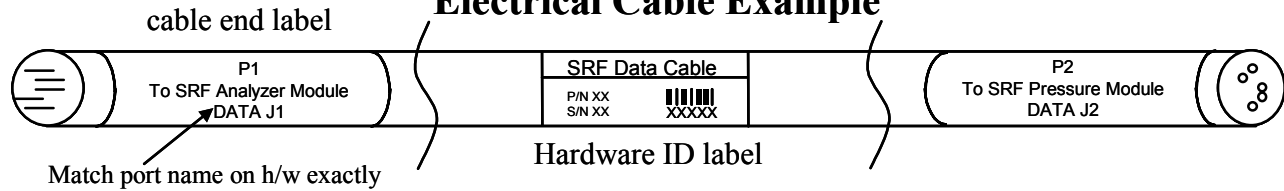

Hose Example

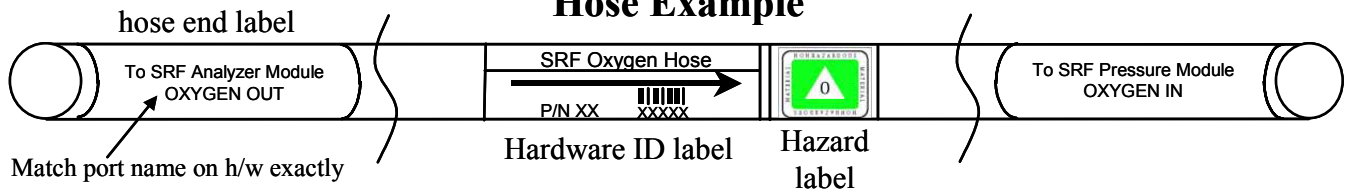

Also acceptable:

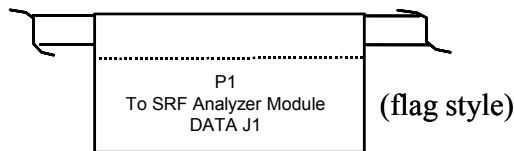

Notes:

Electrical cables/ports: “P” designates cable end plugs and “J” designates receptacles on hardware regardless of gender (pins/sockets).

Hose End Labels: The first line of the end label may be left off (as shown above) if the hose end does not have a specific identifier. In this case, only the second and third lines are needed. If hose ends must be identified, do not use a “P” number.

Hose Identifying Labels: Flow direction should be shown if the hose ends are not interchangeable.

FIGURE C.3.4.4.2.1-1 CABLE AND HOSE LABELING

C.3.4.4.2.2 COLOR CODING

Color coding should only be used to enhance the ability of the ISS crew to perform tasks.

- A. Red, yellow, and orange must only be used to mark emergency use, caution, and warning labels. See section C.3.5.9 for Caution & Warning labeling requirements.
- B. Hazard Labels – Hazard labels have their own, unique coding scheme, of which color is one factor. See Section C.3.5.9.I for instructions.
- C. Identification/Connectivity – Color coding used for component identification or to denote connectivity relationships must combine color with text such that when those components are referred to within procedures, it is clear which components the procedures are referring to.
- D. Color Difference
 - (1) The colors chosen must be easily distinguished from one another within the same system or integrated rack.
 - (2) Each color must always be associated with a single meaning within the same system or integrated rack.
- E. Number of Colors – No more than 9 colors, including white and black, must be used in a coding system.
- F. Markings/Background Color – Markings and background colors on labels must have sufficient contrast such that the labels are readable in ambient ISS lighting conditions. Labels should adhere to the accepted combinations of markings and background color listed below:

Marking	Background
Black	White
Black	Yellow
Black	Silver (metalphoto labels)
White	Black
White	Red
White	Grey
Yellow	Blue
Red	White
Blue	Yellow

C.3.4.4.2.3 LOCATION AND ORIENTATION CODING

A. Subrack Location Codes:

- (1) At the Rack Level - Subrack location codes must be placed along the inside surface of the seat track at intervals equal to the individual rack's smallest drawer unit (e.g: 4 PU (7 inches) for U.S. payloads, different for IP racks), as shown in Figure C.3.4.3-1. Each letter/number pair must be 18 point font and placed at the top of the particular drawer interval. Locations other than the inside of the seat track are permissible only if there is a permanent obstruction that would cover the labels.
- (2) For Control Panels That Control Multiple Subracks – Each subrack's controls must be mapped to its location using the letter/number code (e.g. "A1", "A2", "B1", "B2", etc.), and a graphic (matrix with appropriate box checked) showing the individual locker's location in the rack. See Figure C.3.4.3-2 for examples.

B. Access Panels - Maintenance access panels must be labeled to assist the crew in locating the panel for maintenance activities.

- (1) Access panel identification labels should be located in the upper left corner position on the panel with respect to the local vertical orientation.
- (2) Access panel identification labels for access panels on the side or back of a rack must be labeled as in Figure C.3.4.3-1 and include:
 - The OpNom for the rack (e.g. "SRF").
 - Its height location using the subrack location code becomes part of the OpNom (e.g. "C3") .
 - Its left, right, or back location on the rack preceded by a hyphen (e.g. "-L" for left, "-R" for right, "-B" for back).becomes part of the OpNom for any part the crew sees

For example, a completed access panel label might be "SRF C3-L" or "SRF C3-R".

C. Alignment Marks/Interface Identification

- (1) Alignment Marks – Alignment marks or other orientation markings must be used to aid the crew with the installation/mating of equipment when the hardware requires a specific orientation.
- (2) Visibility – Alignment marks, arrows, or other labels showing required orientation must be visible during alignment and attachment.

- (3) Tethered Equipment – Interface identification should not be used for movable items tethered to a mating part (e.g., dust cap for an electrical connector, hinged lid for a stowage container).

C.3.4.5 OPERATING INSTRUCTION LABELS

Operating instruction labels are labels (affixed to hardware) that contain procedural steps. The procedural text should conform to ODF standards as documented in ODF Standards, SSP 50253 and be approved by the appropriate IP ODF component board. For US payloads, submit ECR to USPODFCB for review and approval.

C.3.4.6 STOWAGE CONTAINER LABELING

This section applies to stowage containers or kits provided by the payload, located within the payload, not in general ISS stowage containers. A standard stowage OpNom/contents label (see example g in Figure C.3.4.1.D-1) exists that can be ordered for the purpose of meeting the below requirements.

- A. Each stowage container must display the contents on its front surface visible to the crewmember. All contents must be identified using the approved OpNom. If the available marking space on a sub-container is insufficient to display the complete content titles, a contents list must be displayed elsewhere and clearly identified as belonging to the sub-container.
- B. Provisions should be made to permit in-flight revisions to or replacement of stowage labels on all stowage containers.
- C. Subdivided Containers:
- D. Individual Crew Items – Items allocated to a specific crewmember should be identified on the contents list with the user's title, name, or other coding technique.
- E. Tool/Accessory Kit Labeling – Containers with designated locations for placement of equipment set (e.g., socket wrenches in a tool kit) should have each location identified with the OpNom of the item stowed.
- F. Containers containing multiple quantities of the same item should use a dash followed by a number, after the name, to indicate the quantity (i.e. "TEST TUBES - 4", indicates there are four test tubes in the container).

C.3.4.7 GROUPED EQUIPMENT ITEMS

- A. Functional groups of three or more equipment items (i.e. displays, controls, switch positions, connectors, LEDs, etc.) must be identified as a group (e.g., by common color, by boundary lines). Functional groups of equipment items are all associated or connected with a common system or purpose. (e.g., CABIN AIR, FURNACE A, EXPERIMENT “M”, PANEL LIGHTING). Two functionally related items should be grouped when such grouping provides clarification of purpose and/or distinguishes them from surrounding items. See Figure C.3.4.7–1 for grouping label examples.
- B. Labels must be located above the functional groups they identify.
- C. When a line is used to enclose a functional group and define its boundaries, the labels must be centered at the top of the group, in a break in the line. When it is not possible to center the text at the top, the text may be placed elsewhere along the perimeter of the boundary line, but local vertical orientation or the text must be maintained.
- (1) The width of the line must not be greater than the stroke width of the letters.
 - (2) The line must form an enclosed rectangle, or box, with rounded corners. Deviations from the rectangular shape are allowed when dimensional restrictions preclude a perfect rectangle.

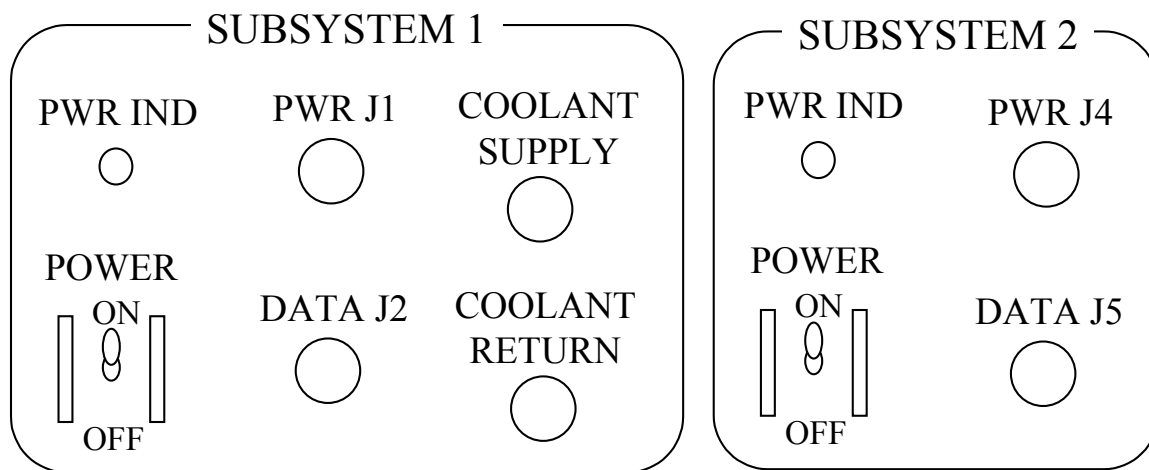

FIGURE C.3.4.7–1 GROUPING LABEL EXAMPLES

C.3.4.8 CAUTION AND WARNING LABELS

Caution and warning labels are required for indicating potentially undesirable conditions. See Figure C.3.4.8-1 for examples. The PSRP or an OZ3 safety representative must approve non-standard Caution and Warning label wording.

- A. Caution and warning labels must be standardized between and within systems.
- B. Caution and warning labels must be distinct from one another.
- C. Caution and warning labels must identify the type of hazard and the action that would prevent its occurrence.
- D. The caution and warning markings must be located in a visible area.
- E. Emergency-Use Label Specifications
 - (1) Labels on emergency-use items (e.g., repair kits, emergency lighting, fire extinguisher, etc.) must be surrounded by diagonal red and white stripes either on the item or adjacent to it, and on its container.
 - (2) The emergency type warning stripes must be alternate red and white.
 - (3) The red and white stripes should be of equal width.
 - (4) There must be no fewer than four red stripes and three white stripes.
 - (5) The striping must be applied at a 45 degree angle rotated clockwise from the vertical.
 - (6) The striping must begin and end with a red stripe.
 - (7) The text must be white letters on the red background or red letters on a white background.
- F. Caution And Warning Label Specifications
 - (1) Labels on Caution and Warning items must be either on the item or adjacent to it, and on its container. Caution/warning labels must be surrounded by diagonal yellow and black stripes.
 - (2) The caution/warning type stripes must be alternate yellow and black.
 - (3) The yellow and black stripes should be of equal width.
 - (4) There must be no fewer than four yellow stripes and three black stripes.

- (5) The striping must be applied at a 45 degree angle rotated clockwise from the vertical.
- (6) The striping must begin and end with a yellow stripe.
- (7) The text must be black letters on the yellow background.
- (8) For Caution and Warning items located within a storage container, the Caution and Warning label must be applied to the outside of the container, and the titles of the Caution and Warning items must be included on the marking.

G. Switches and Buttons

- (1) The striping around a switch or button should not be wider than 25mm (1 in.) or narrower than 3 mm (0.125 in.).
- (2) If one side of a switch or button has less than 3 mm (0.125 in.) space, no striping should be applied to that side.

H. Hazard Labels

- (1) Chemicals – The standard hazard class decals must be used to identify the proper hazard class of payload chemicals (i.e. chemicals in solid, liquid, or gaseous states), as deemed by the payload's toxicology representative. The developer may obtain these decals from JSC 27260, Decal Process Document and Catalog, or must produce identical labels. See NSTS 07700, Volume 14, Appendix 9, Section 5.6.3 for hazard class definitions.
- (2) Other hazards - When biological, radiation, sharps, battery, or other hazards are identified by safety personnel, the appropriate standard label (if available) must be applied in a prominent location. The developer may obtain these decals from JSC 27260, Decal Process Document and Catalog, or must produce identical labels.

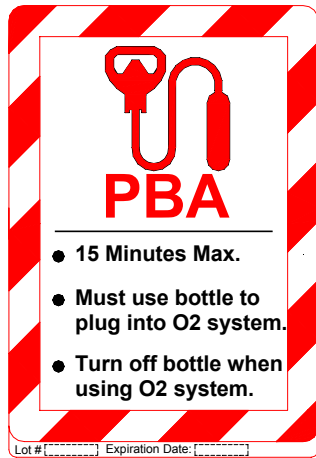

Emergency Use Label Example



Caution/Warning Label Example



Toxic Hazard Label Examples

FIGURE C.3.4.8-1 CAUTION AND WARNING LABEL EXAMPLES

C.3.4.9 ALPHANUMERIC

C.3.4.9.1 FONT STYLE

- A. The font style used on decals, placards, engravings, and labels must be Helvetica or Arial. If these are not available, a similar sans serif font is acceptable.
- B. Stenciled Characters – Stencil-type characters should not be used on display/control panels or other equipment.

C.3.4.9.2 PUNCTUATION

Punctuation should not be used on labels except as a part of the approved OpNom or as otherwise noted in this appendix.

C.3.4.9.3 SPECIAL CHARACTER

- A. Subscript and Superscript Size – Subscripts and superscripts should be 0.6 to 0.7 times the height of associated characters.
- B. Subscripts – Numeric subscripts and upper case letter subscripts should be centered on the baseline of associated characters.
- C. Lower Case Letter Subscripts –The base of lower case letters and the ovals of g, p, q, etc., should be at the same level as the base of adjacent capital letters.
- D. Degree Symbol – The degree symbol should be centered on an imaginary line extended from the top of the F or C symbols.
- E. Pound or Number Symbol (#) – The pound or number symbol should be centered on an imaginary line extended from the top of the associated numerals and placed two stroke widths away from them.

C.3.4.9.4 LINE SPACING

- (1) The spacing between lines of related text should be 0.5 of upper case letter height.
- (2) Spacing between headings and text should be 0.6 to 1.0 of upper case letter height.

C.3.4.10 IMS BARCODES

PDs will coordinate with NASA/JSC organization OC for Inventory Management System (IMS) barcodes.

All equipment must have an IMS barcode in accordance with SSP 50007. IMS barcodes placeholders must be present on engineering drawings, if the standard hardware ID label (with IMS barcode included) is not used. If the PD orders their IMS barcodes from the DDPF, the Decal Catalog decal part number should be included in a note on the engineering drawing.

C.3.6 SCALE MARKING

A. Accuracy

- (1) The precision of scale marking should be equal to or less than the precision of the input signal.

- (2) In general, scales that are to be read quantitatively to the nearest graduation mark should be designed so that interpolation between graduation marks is not necessary. Interpolation should be limited to one half the distance between minor graduation marks.
- (3) Scales should have a zero reference.
- (4) If precise measurements are needed, scale graduation marks should be marked clearly to allow for unambiguous measurements.

B. Interval Values

- (1) The graduation intervals should progress by 1, 5, or 2 units of decimal multiples thereof.
- (2) The number of graduation marks between numbered graduation marks should not exceed 9.

C. Scale Markings

- (1) The minimum width of a major graduation should be 0.89 mm (0.035 in.), the minimum width of an intermediate graduation should be 0.76 mm (0.030 in.), and the minimum width of a minor graduation should be 0.64 mm (0.025 in.).
- (2) Major, intermediate, and minor graduation marks must be graduated in size.
- (3) Deleted.
- (4) Graduation marks should be spaced a minimum of 1.5 mm (0.06 in.) between centerlines.