

SPECIFICATIONS	
UNITS	MILLIMETERS
TOLERANCES	± 1 mm UNLESS STATED
MATERIAL	1mm steel, zinc seal
FINISH	1. Phosphate passivate 2. Mask where indicated 3. Powder coat white

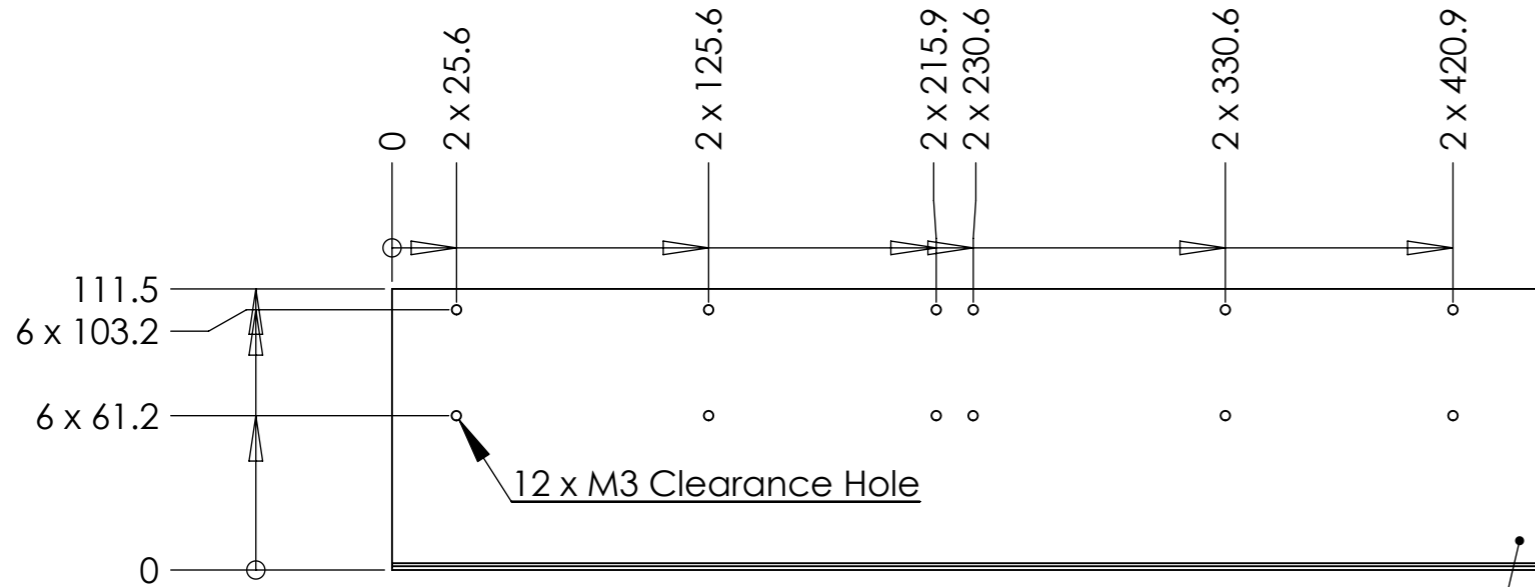

NOTE: These faces are not to be powder coated

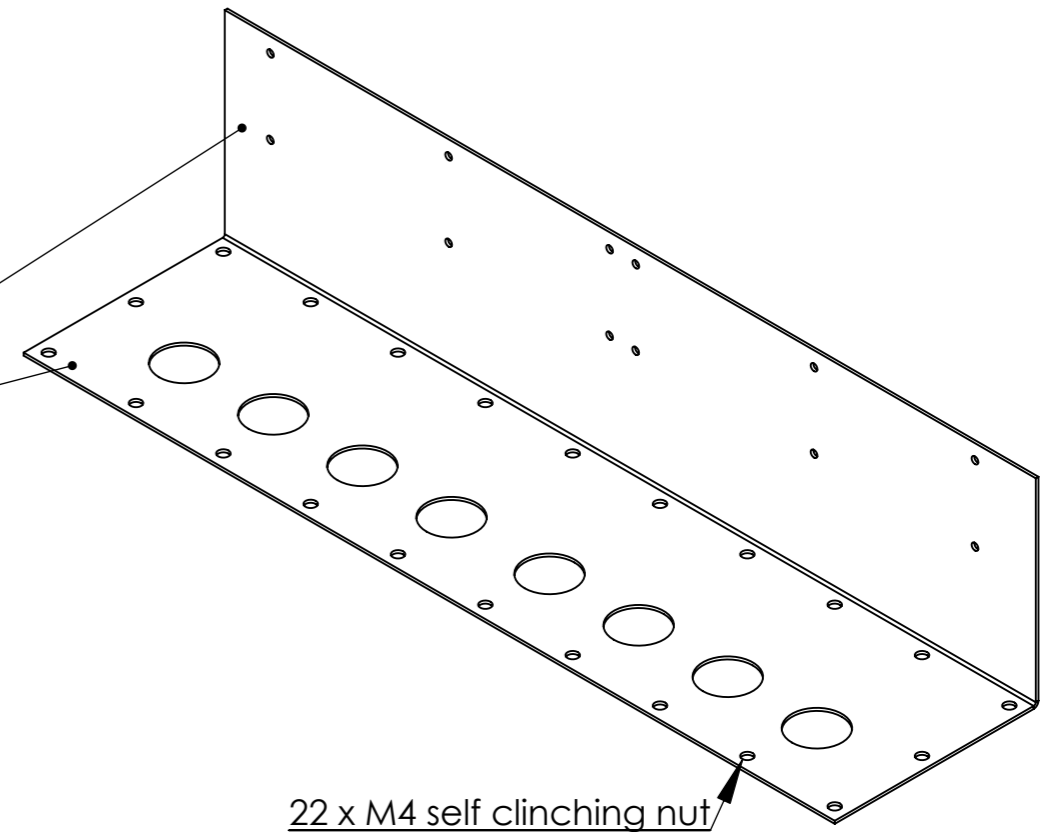

22 x M4 self clinching nut

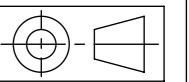
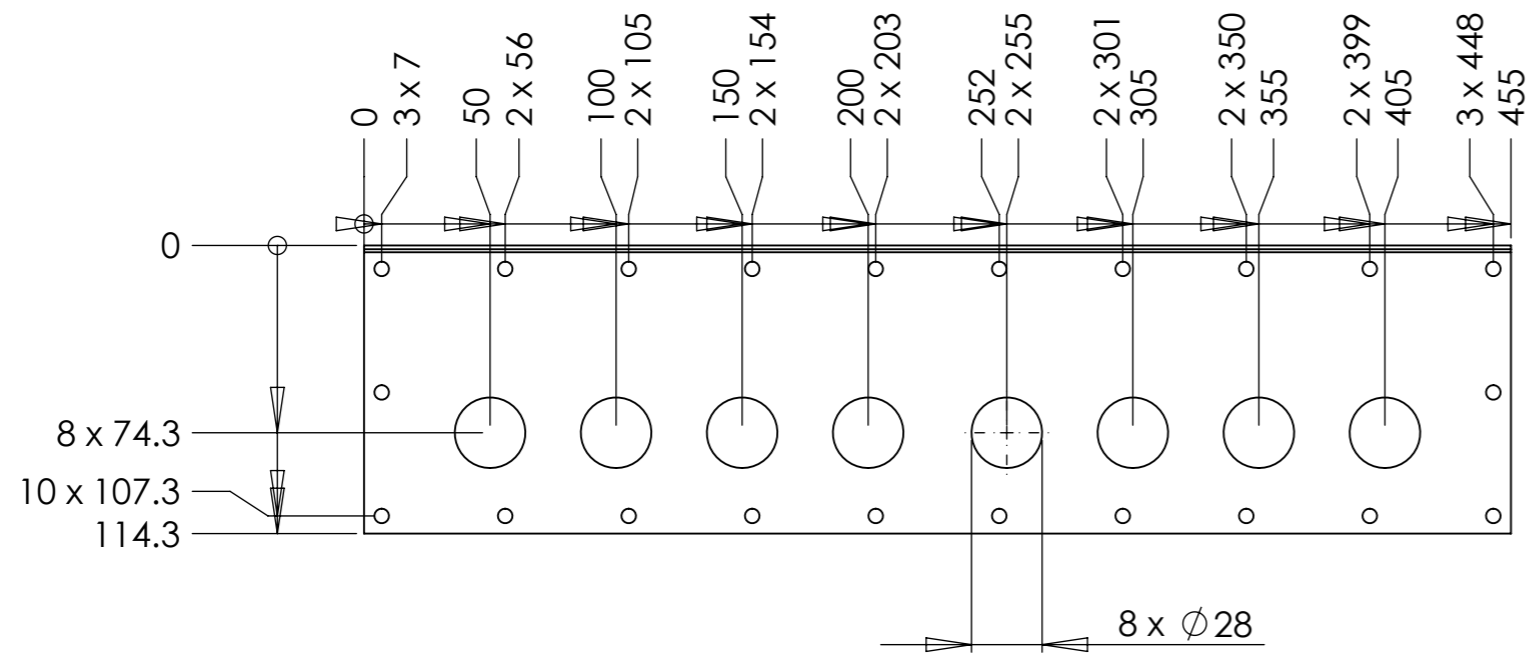

 <b>POSEIDON SCIENTIFIC INSTRUMENTS</b> <small>17 QUEEN VICTORIA ST, FREMANTLE WA 6160 PH: (08) 9430 6639 FAX (08) 9335 4650</small>			
DRAWING NAME			
MWA Connector Panel			
SIZE	DRAWN BY	DRAWING FILENAME.	
A3	C.Coleman	MWAM014 Connector panel.SLDDRW	
SCALE	DATE	COMPONENT NAME	REV
1:3	5/01/2010	MWAM014 Connector panel.SLDPRT	B
SHEET			
1 of 2			

SPECIFICATIONS	
UNITS	MILLIMETERS
TOLERANCES	± 1 mm UNLESS STATED
MATERIAL	1mm steel, zinc seal
FINISH	1. Phosphate passivated 2. Mask where indicated 3. Powder coat white

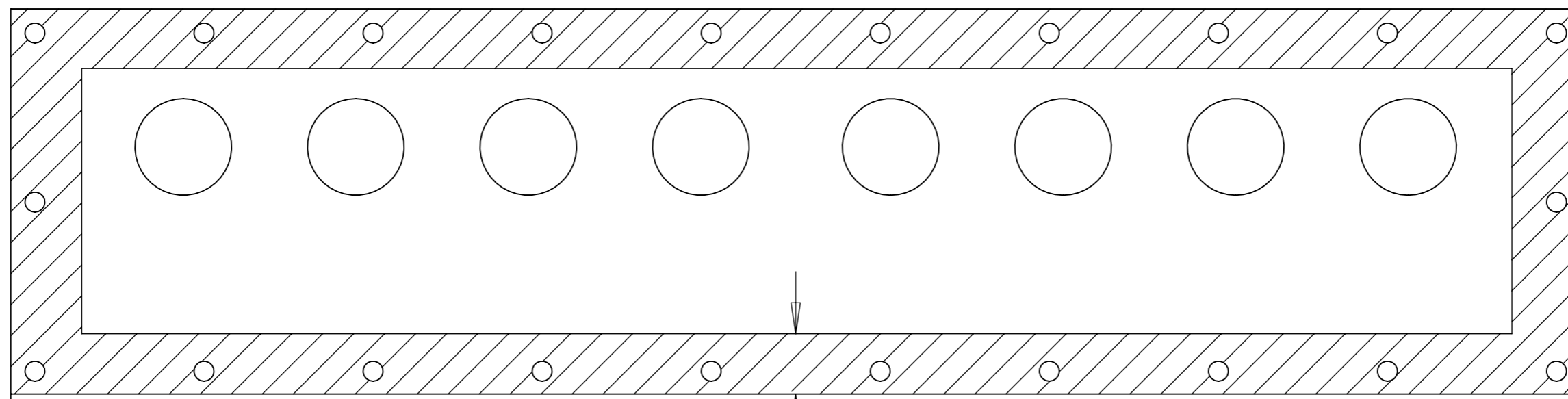

Mask 20mm wide (typ) all around

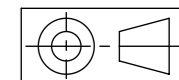

NOTE: Mask holes from opposite side to prevent over spray

 <b>PSI</b> POSEIDON SCIENTIFIC INSTRUMENTS <small>17 QUEEN VICTORIA ST, FREMANTLE WA 6160 PH: (08) 9430 6639 FAX (08) 9335 4650</small>			
DRAWING NAME			
MWA Connector Panel			
SIZE	DRAWN BY	DRAWING FILENAME.	
A3	I. HART	MWAM014 Connector panel.SLDDRW	
SCALE	DATE	COMPONENT NAME	REV
2:3	5/01/2010	MWAM014 Connector panel.SLDPRT	B
SHEET			
2 of 2			