

CABLE DRAWING: **CAB-0XXX (SALEM CODE)**

DRAWING TITLE:
Power Supply AUX Cable

DRAWING NO.: MWACAB-0009	DRAWN BY: DRC	DATE: 17-Dec-09	REV: A
		SHEET: 1 of 2	

Cable Detail:

Connectors:	Description	Parts (Qty)
PSU-AUX	Pre-made H-SN-14 from Cosel with cable supplied	See Note1 Below(1)
PCB-AUX-S	TYCO/AMP - 102241-1 Crimp Housing, 3Way	See Note2 Below(1)
PCB-AUX-P	TYCO/AMP - 87667-5 - Crimp Socket, 26-22AWG	See Note3 Below(3)
Conductors:	Supplied with H-SN-14 above.	See Note1 Below

Overall Length ??+/-5mm

Notes:

1. The pre-made cosel connector and cable can be supplied from PowerBox #H-SN-14. Any equivalent will be OK refer to data sheets supplied with this drawing.
2. The Housing can be supplied from Farnell #182-2573. Any equivalent will be OK refer to data sheets supplied with this drawing.
3. The Housing Pins can be supplied from Farnell #973-294. Any equivalent will be OK, but must match the housing refer to data sheets supplied with this drawing.

Typical Drawing:

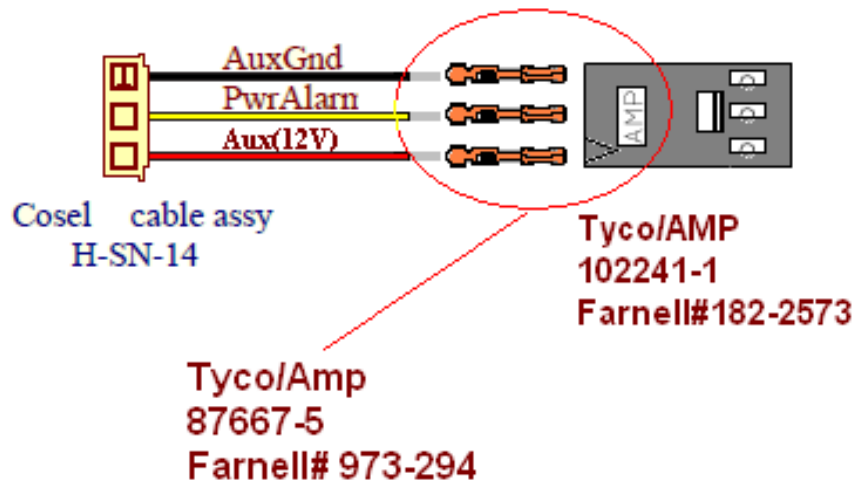

Connection Table:

PSU-AUX	Description	PCB-AUX
Pins(3)		Pins(3)
1	AuxGnd	1
2	PwrAlarm	2
3	Aux(12V)	3

REVISION

Date	Rev	Remarks
14/12/09	A	Draft

CABLE DRAWING: **CAB-0XXX (SALEM CODE)**

DRAWING TITLE:
Power Supply AUX Cable

DRAWING NO.: MWACAB-0009	DRAWN BY: DRC	DATE: 17-Dec-09	REV: A
		SHEET: 2 of 2	

Assembly Details:

CRIMPING & STRIPPING

Wire Preparation

The wire must be stripped to the dimension provided in Figure 2.

Do not nick, scrape, or cut the wire conductor during the stripping operation.

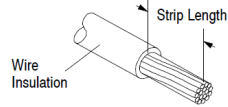
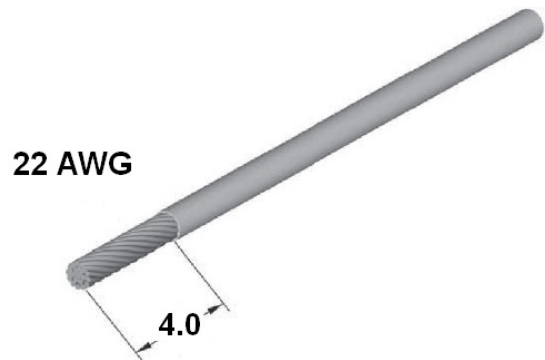

Figure 2

WIRE SIZE RANGE, (AWG)	INSUL DIA MAX.	STRIP LENGTH	WIRE BARREL		INSUL BARREL CRIMP WIDTH
			CRIMP HEIGHT	CRIMP WIDTH	
20	•	4.78-3.58	0.94-0.72	1.4	1.57
22	•	4.78-3.58	0.84-0.72		
24	•	4.78-3.58	0.83-0.64		
22	1.55	4.37-2.77	0.97-0.81	1.07	
24	1.55	4.37-2.77	0.86-0.71		
26	1.55	4.37-2.77	0.81-0.71	1.4	
26-30	1.22	4.37-2.77	0.74-0.64		
27, 28	1.02	4.37-2.77	0.61-0.51	0.84	1.4
30, 32	1.02	4.37-2.77	0.61-0.48		



Crimp Length

For optimum crimp effectiveness, the crimp must be within the area shown and must meet the crimp dimensions provided in Figure 3. Effective crimp length shall be defined as that portion of the wire barrel, excluding bellmouth(s), fully formed by the crimping tool.

Figure 3

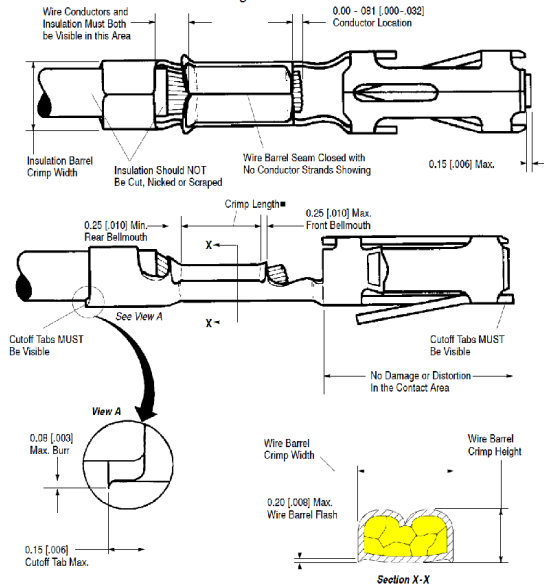

NOTE: Comparing a crimped contact to an uncrimped contact should reveal any fault that may have occurred to front shoulder or locking lances during crimping.

- Effective crimp length shall be 2.67 mm minimum for 20-24 AWG wire, and 2.16 mm minimum for all other wire sizes; and is defined as that portion of the wire barrel fully formed by the tool, excluding the bellmouths.

Connection Detail:

From: (PSU-AUX)
Attached to the PSU Aux connector
To: PCB-AUX)
Attach to the PCB AUX connector

REVISION

Date	Rev	Remarks
14/12/09	A	Draft

Harness to use the function of the output module is prepared in ACE series.

ACE Series

Mating harness

Model	Harness model #	Contents
ACE series	H-SN-14	Harness for using AUX and PR alarm of CN1.
	H-SN-16	Harness for using all function of output modules. (CN2)
	H-SN-17	Harness for using all functions except remote sensing of the output modules. (CN2)
	H-SN-18	Harness for using remote ON/OFF of output module S, T, U.(CN2)

●Model number
H-SN-14

Housing : XHP-3 (J.S.T.)
Pin : SXH-001T-P0.6 (J.S.T.)

●Type

●Wire

Pin #	Wire	AWG	Color	Length l (mm)
1	UL1007	22	black	500
2	UL1007	22	yellow	500
3	UL1007	22	red	500

●Model number
H-SN-16

Housing : PHDR-10VS (J.S.T.)
Pin : SPHD-002T-P0.5 (J.S.T.)

●Type

●Wire

Pin #	Wire	AWG	Color	Length l (mm)
1	UL1061	28	yellow	500
2	UL1061	28	orange	500
3	-	-	-	-
4	-	-	-	-
5	UL1061	28	blue	500
6	UL1061	28	black	500
7	UL1061	28	red	500
8	UL1061	28	red	500
9	UL1061	28	black	500
10	UL1061	28	black	500

* The even number pin side of the connector is the same wiring as the odd number pin side.

●Model number
H-SN-17

Housing : PHDR-10VS (J.S.T.)
Pin : SPHD-002T-P0.5 (J.S.T.)

●Type

* Pin #7 and #8 are shorted with harness and also pin #9 and #10.

●Wire

Pin #	Wire	AWG	Color	Length l (mm)
1	UL1061	28	yellow	500
2	UL1061	28	orange	500
3	-	-	-	-
4	-	-	-	-
5	UL1061	28	blue	500
6	UL1061	28	black	500
7	UL1061	28	red	30
8	UL1061	28	red	30
9	UL1061	28	black	30
10	UL1061	28	black	30

* The even number pin side of the connector is the same wiring as the odd number pin side.

●Model number
H-SN-18

Housing : PHR-2 (J.S.T.)
Pin : SPH-002T-P0.5S (J.S.T.)

●Type

●Wire

Pin #	Wire	AWG	Color	Length l (mm)
1	UL1007	26	yellow	500
2	UL1007	26	orange	500

Option

J-29

REVISIONS				
ZONE	LTR	DESCRIPTION	DATE	APPD
C		REV LOC & DIST AD-4171	3-90	BF
D		OBS PER 0010-0743-93	9/14/93	PS
E		OBS PER 0010-1031-93	12-7-93	PS
F		OBS PER 0010-1049-93	12-7-93	PS
G		REACT. -11 PER 0010-1231-94	8-23-94	PS
H		REACT. -26 PER 0010-1273-94	8-23-94	PS
J		REV PER 0010-0641-95	5-18-95	PS
K		REV PER 0010-0187-95	1-24-96	SAS
L		REV PER 0310-0074-97	3-5-97	JS
M		REV PER 0310-0484-97	2-6-98	BS

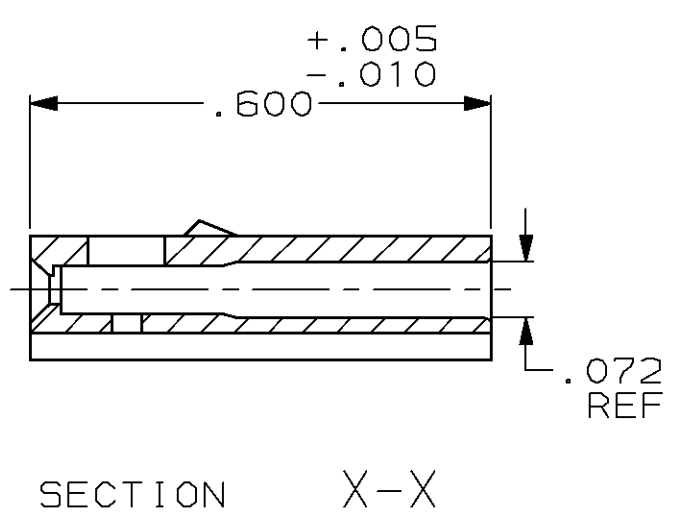
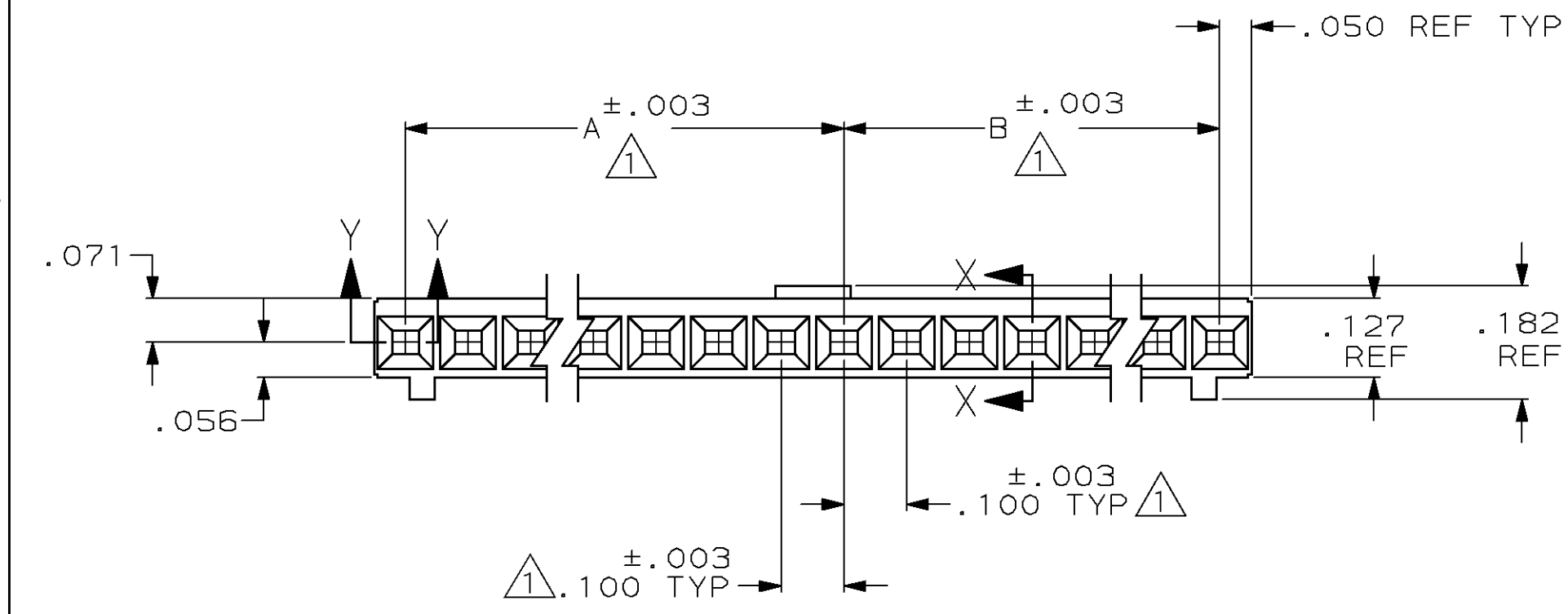
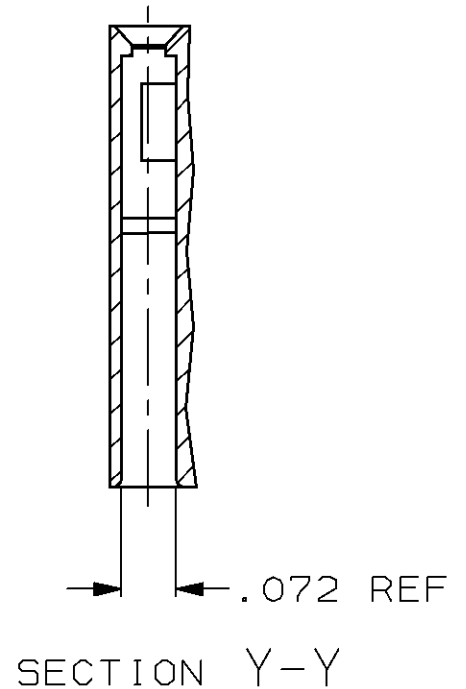
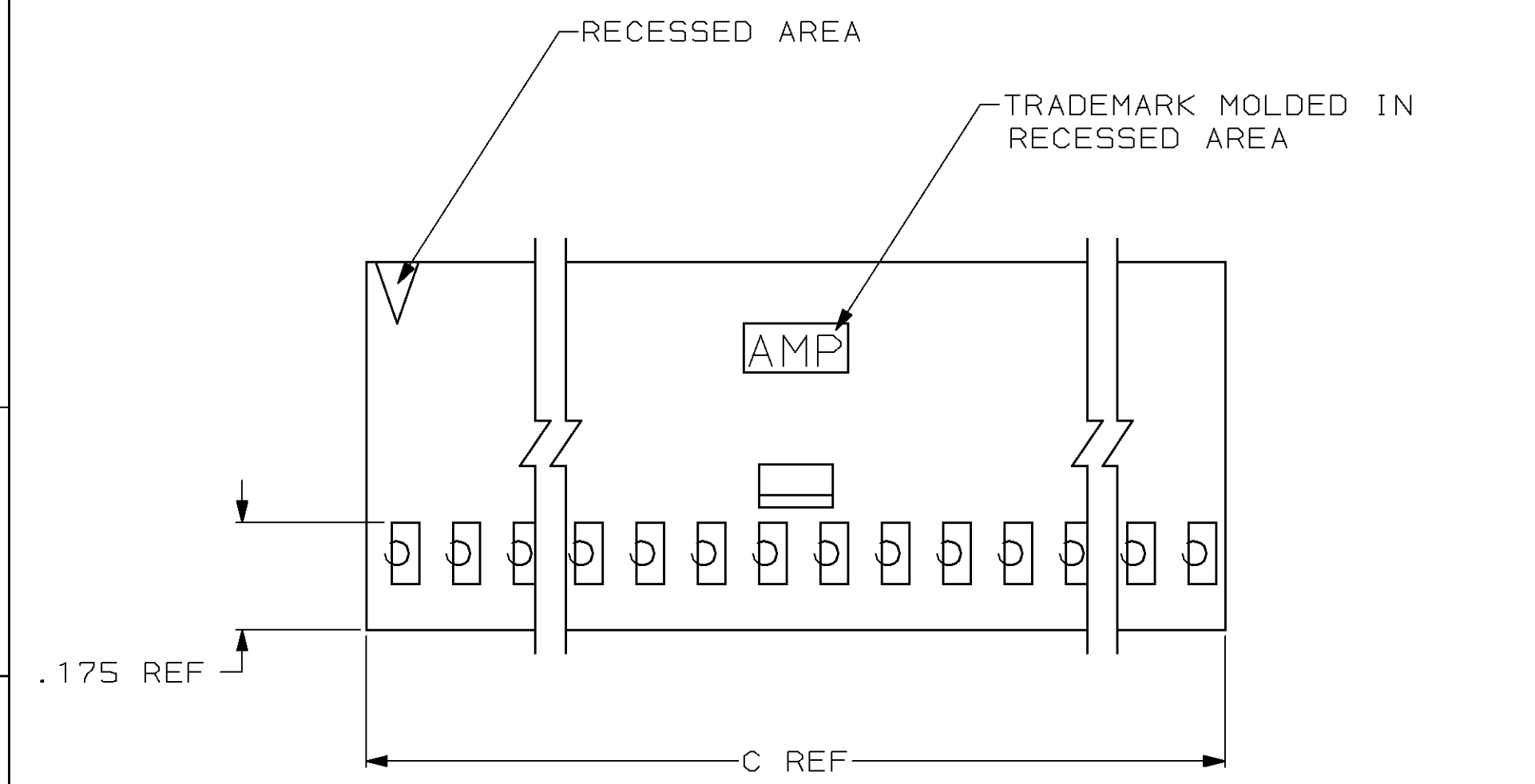

C	B	A	NO OF POS	PART NUMBER
3.600	1.700	1.800	36	3-102241-4
3.500	1.700	1.700	35	3-102241-3
3.400	1.600	1.700	34	3-102241-2
3.300	1.600	1.600	33	3-102241-1
3.200	1.500	1.600	32	3-102241-0
3.100	1.500	1.500	31	2-102241-9
3.000	1.400	1.500	30	2-102241-8
2.900	1.400	1.400	29	2-102241-7
2.800	1.300	1.400	28	2-102241-6
2.700	1.300	1.300	27	2-102241-5
2.600	1.200	1.300	26	2-102241-4
2.500	1.200	1.200	25	2-102241-3
2.400	1.100	1.200	24	2-102241-2
2.300	1.100	1.100	23	2-102241-1
2.200	1.000	1.100	22	2-102241-0
2.100	1.000	1.000	21	1-102241-9
2.000	.900	1.000	20	1-102241-8
1.900	.900	.900	19	1-102241-7
1.800	.800	.900	18	1-102241-6
1.700	.800	.800	17	1-102241-5
1.600	.700	.800	16	1-102241-4
1.500	.700	.700	15	1-102241-3
1.400	.600	.700	14	1-102241-2
1.300	.600	.600	13	1-102241-1
1.200	.500	.600	12	1-102241-0
1.100	.500	.500	11	102241-9
1.000	.400	.500	10	102241-8
.900	.400	.400	9	102241-7
.800	.300	.400	8	102241-6
.700	.300	.300	7	102241-5
.600	.200	.300	6	102241-4
.500	.200	.200	5	102241-3
.400	.100	.200	4	102241-2
.300	.100	.100	3	102241-1

- ① CAVITY LOCATION DIMENSIONS INCREASE IN INCREMENTS OF .100 TOLERANCE NON-CUMULATIVE
- ② USE EXTRACTION TOOL 91052-1 TO REMOVE RECEPTACLE CONTACTS
- ③ OBSOLETE PART NUMBER

DO NOT SCALE PRINT. UNLESS SPECIFIED DIMENSIONS IN INCHES TOLERANCES ON: 2 PLC DEC ± - 3 PLC DEC ± .005 ANGLES ± -		DR 8-2-78 D FABIAN		AMP INCORPORATED Harrisburg, Pa. 17105	
MATERIAL FLAME RETARDANT GLASS FILLED NYLON COLOR: BLACK		CHK 10-27-78 B WOLFE			
FINISH -		APPD 10-27-78 D LITTLE		NAME CONN HOUSING, CRIMP SNAP-IN MOD IV, SINGLE ROW, .100 CENTERS, WITH POLARIZATION & DETENTS	
		APPD 10-27-78 J MULLIGAN		SIZE C 00779	
		PRODUCT SPEC -		DRAWING NO 102241	
		APPLICATION SPEC -		SCALE -	
		WEIGHT -		SHEET 1 OF 1	

THIS DRAWING IS UNPUBLISHED. RELEASED FOR PUBLICATION
 © COPYRIGHT - BY TYCO ELECTRONICS CORPORATION. ALL RIGHTS RESERVED.

LOC	DIST	REVISIONS					
AD	00	P	LTR	DESCRIPTION	DATE	DWN	APVD
			B	RELEASED	-	-	-

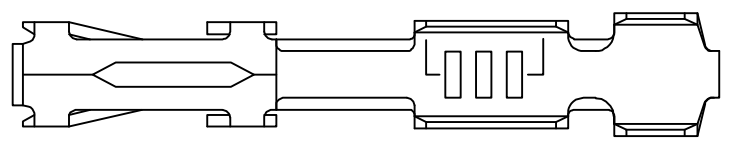

1. LOOSE PIECE TERMINAL MUST MEET ALL APPLICABLE STRIP SPECIFICATIONS IN ADDITION TO THOSE SHOWN.
2. .000030 MIN. GOLD OVER .000050-.000100 NICKEL.
3. GOLD FLASH OVER .000050-.000100 NICKEL
.000030 GOLD ON CONTACT AREA.
4. PREPLATING: .000078-.000158 BRIGHT TIN (HALT)
PER 112-20-6
5. .000050 GOLD OVER .000050-.000100 NICKEL.
6. GOLD FLASH OVER .000050-.000100 NICKEL
.000015 GOLD ON CONTACT AREA.
7. GOLD FLASH ON AREA "L"
.000050 GOLD ON CONTACT AREA.
ALL OVER .000050-.000100 NICKEL ENTIRE CONTACT.

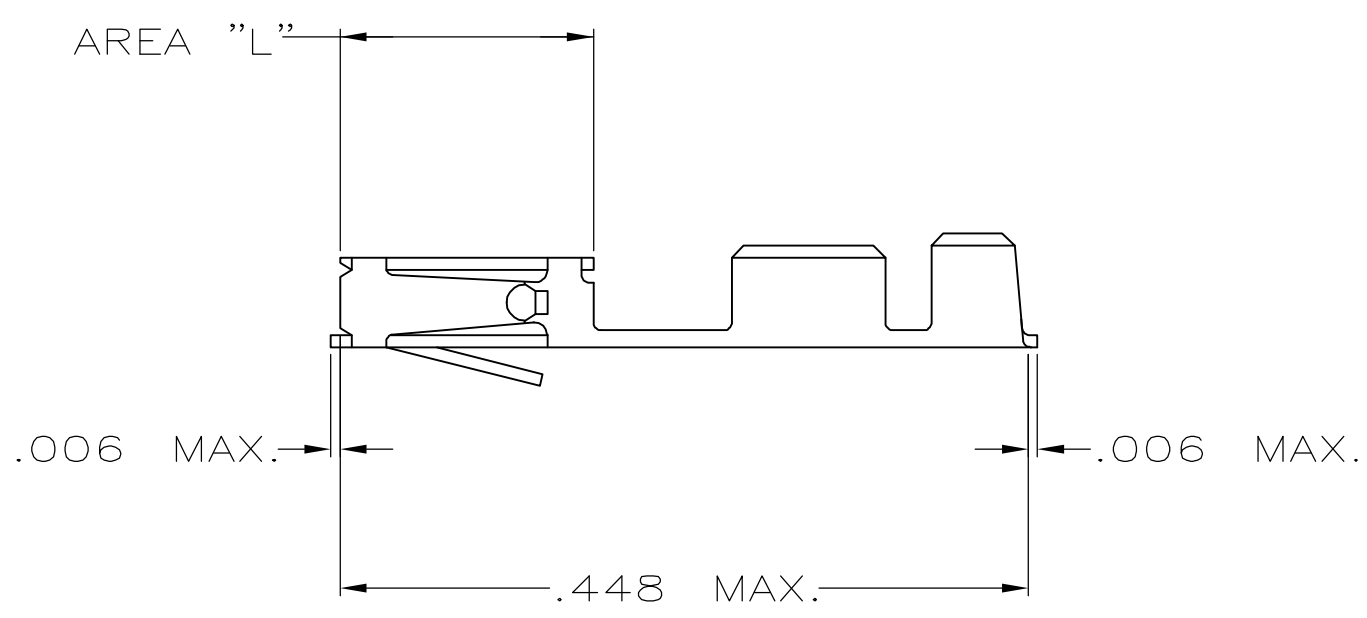

		-	-
OBSOLETE	7	1-87666-6	87667-6
	6	87666-5	87667-5
	5	87666-4	87667-4
	4	87666-3	87667-3
	3	87666-2	87667-2
	2	87666-1	87667-1
FINISH		MAKE FROM STRIP PART NO.	PART NUMBER

THIS DRAWING IS A CONTROLLED DOCUMENT.		DWN M.BINNER 27JUN06	Tyco Electronics Corporation Harrisburg, PA 17105-3608			
DIMENSIONS: INCHES		CHK D.ROHDE 27JUN06				
TOLERANCES UNLESS OTHERWISE SPECIFIED:		APVD D.ROHDE 27JUN06	NAME CONTACT, FEMALE, MOD IV, CRIMP SNAP-IN (LOOSE PIECE)			
0 PLC ± - 1 PLC ± - 2 PLC ± .02 3 PLC ± .005 4 PLC ± .0005 ANGLES ± 0'30"		PRODUCT SPEC -	APPLICATION SPEC -			
MATERIAL SEE TABLE	FINISH SEE TABLE	WEIGHT -	SIZE A3	CAGE CODE 00779	DRAWING NO C-87667	RESTRICTED TO -
CUSTOMER DRAWING			SCALE 8:1	SHEET 1 OF 1	REV B	