

8 7 6 5 4 3 2 1

REVIEWS				
ECD	REV.	DESCRIPTION	DATE	APPROVED
	01	INITIAL RELEASE	9/26/06	
32-2002	A	RELEASE FOR FLIGHT BUILD		

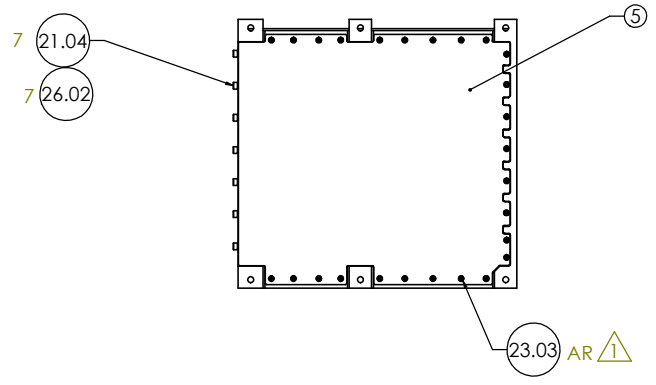
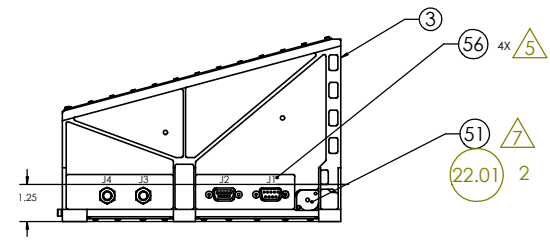
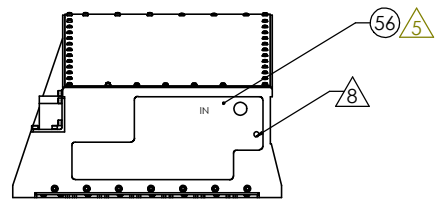
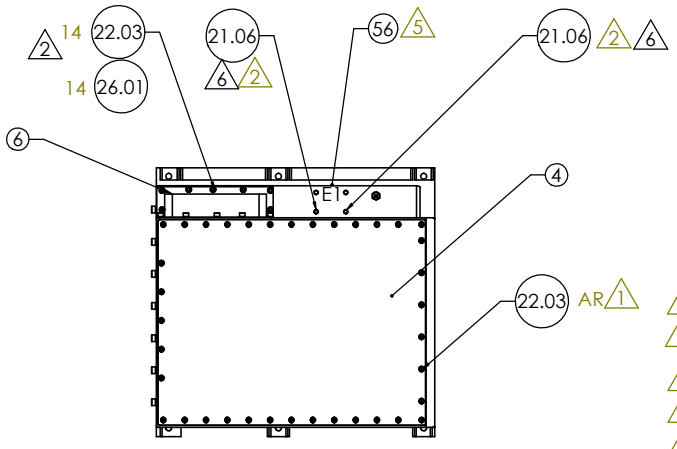
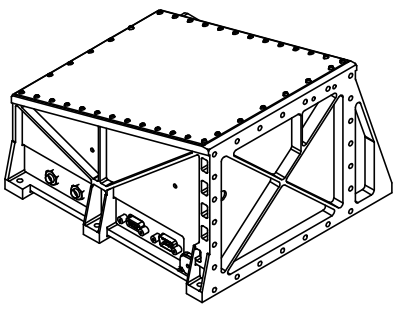

- 1 TEMPORARILY SECURE F/N 4 AND 5 USING F/N 22.03 AS REQUIRED. DO NOT SPOT BOND AT THIS ASSEMBLY. REMAINING HARDWARE WILL BE INSTALLED AND SPOTBONDED AT NEXT HIGHER ASSEMBLY.
- 2 TORQUE 2-56 HARDWARE TO 48 IN-OZ. TORQUE 4-40 HARDWARE TO 5 IN-LBS.
- 3 FEED 1553 CONNECTORS THRU MOUNTING HOLE AND SECURE WITH SUPPLIED NUT. TORQUE TO 25 IN-LBS. SPOT BOND USING F/N37.
- 4 SOLDER F/N'S 35, 42, 50, 10 AND 15. SECURE ALL WIRING AND COMPONENTS USING F/N 46.
- 5 MARK CONNECTOR REFERENCES "J1-J4", "IN", AND "E1" IN 12-25 HIGH CHARACTERS USING F/N 56. LOCATE APPROXIMATELY WHERE SHOWN.
- 6 SPOT BOND USING F/N 37.
- 7 DUST COVER, F/N/ 51 IS TO BE SECURED DURING STORAGE AND SHIPMENT. PRIOR TO PURGING, LOSSEN HARDWARE SLIDE OPEN TO EXPOSE VENT FILTER.
- 8 ESD BANANA PLUG GROUND LOCATION.
- 9 CUT 2 PIECES OF BUS WIRE 0, 01" DIAMETER AND PLACE ACROSS SHELF. PERPENDICULAR TO EACH OTHER. APPLY F/N 37 USING A SMALL FILET BEAD ALL AROUND PERIMETER OF SHELF. GENTLY PRESS F/N 33 IN PLACE. SPOT BOND OUTER EDGE IN TWO PLACES. TRIM EXPOSED BUS WIRE AFTER F/N 37 HAS CURED.
- 10 MOUNT F/N 55 USING F/N 25.01 AS SHOWN. TORQUE TO 5 IN-LBS AND SPOTBOND USING F/N 37. PRIOR TO INSTALLATION OF F/N 9 AND 54.
- 11 ROUTE CABLE, FROM F/N 9, THRU GROOVES ON F/N 55. SECURE IN PLACE WITH F/N 54 USING HARDWARE SHOWN.
- 12 EPOXY BONDABLE TERMINALS F/N'S 28, 32 AND 44 TO F/N 3 USING F/N 16. ALLOW 72 HOURS TO CURE BEFORE SOLDERING PER NOTE 4.
- 13 EPOXY BONDABLE TERMINAL F/N 32 TO U1, U2 AND U3 AS SHOWN USING F/N 16. ALLOW 72 HOURS TO CURE BEFORE SOLDERING.
- 14 EPOXY BONDABLE TERMINAL F/N 28 TO U2 AS SHOWN USING F/N 16. ALLOW 72 HOURS TO CURE BEFORE SOLDERING F/N 31, F/N 43 AND F/N 15 PER NOTE 4.
- 15 BOND F/N 29 LEADS TO F/N 3 USING F/N 46.
- 16 EPOXY BOND F/N 30 USING F/N 46. ROUTE WIRES DIRECTLY TO J2 BULKHEAD CONNECTOR. SPOTBOND WIRING PER NASA-STD-8739.1 USING F/N 46. TERMINATE IN J2, F/N 7, PER NASA-STD-8739.1.
- 17 BOND U4 AND U5 AS SHOWN USING F/N 46.
- 18 APPLY CONFORMAL COAT F/N 48, OVER EXPOSED SOLDER JOINTS AND PADS AFTER INSPECTION.
- 19 TORQUE 4-40 HARDWARE TO 48 IN-OZ.
- 20 SECURE ALL WIRING TO CHASSIS USING F/N 46 PER NASA-STD-8739.1.
- 21 INSTALL AT NEXT HIGHER ASSEMBLY.
- 22 ENCAPSULATE F/N 29 TO F/N3 USING F/N 46.

UNLESS OTHERWISE SPECIFIED:		NAME	DATE	MIT/BU, CRATER PROJECT
DRAWN	CHECKED			TITLE:
DESIGNED	APPROVED			ELECTRONICS ASSEMBLY
ENG. APPR.	ENG. APPR.			CRATER
DATE	DATE			SIZE DWG. NO. REV
				D 32-10200 A
SCALE: 1:5	WEIGHT:			SHEET 1 OF 3

8 7 6 5 4 3 2 1

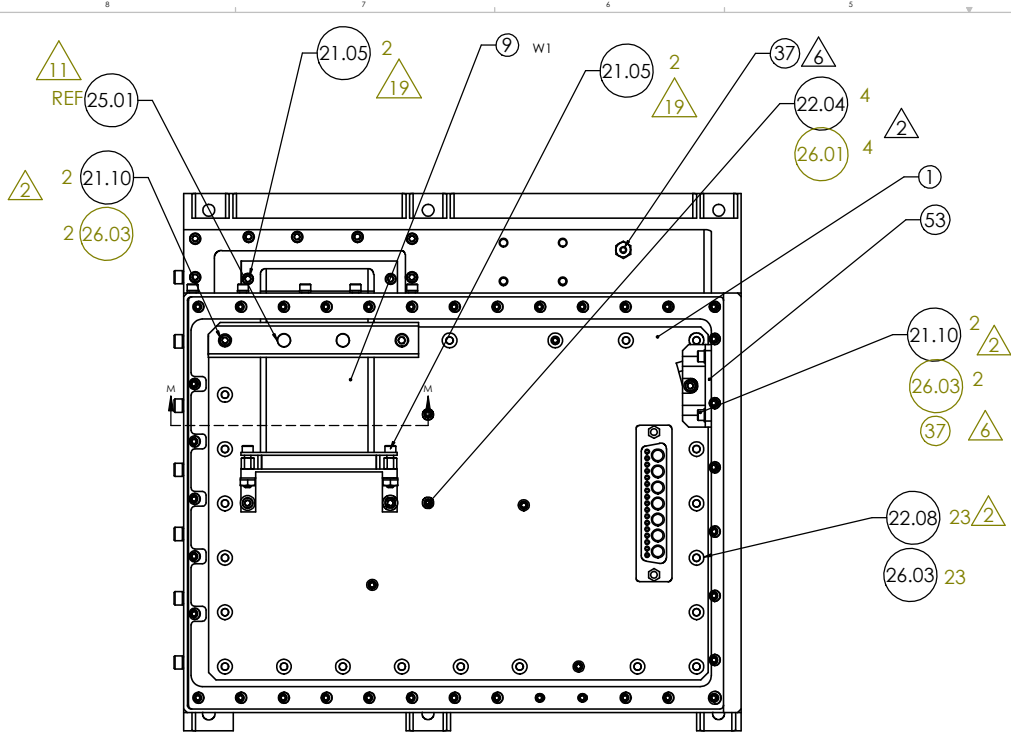

TOP VIEW WITH
TOP COVER REMOVED FOR CLARITY

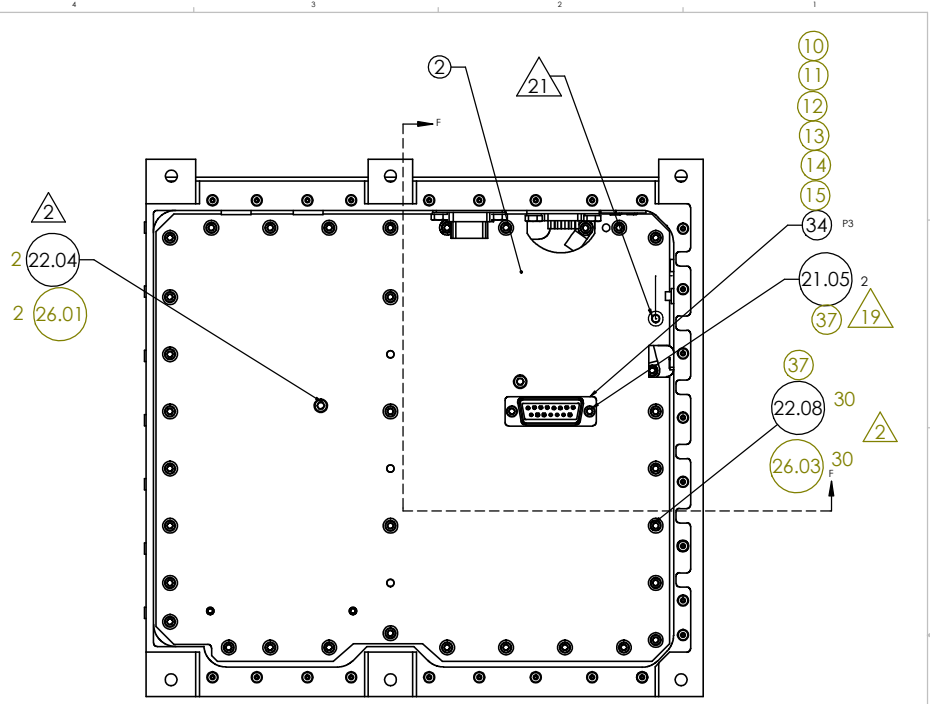

BOTTOM VIEW WITH
BOTTOM COVER REMOVED FOR CLARITY

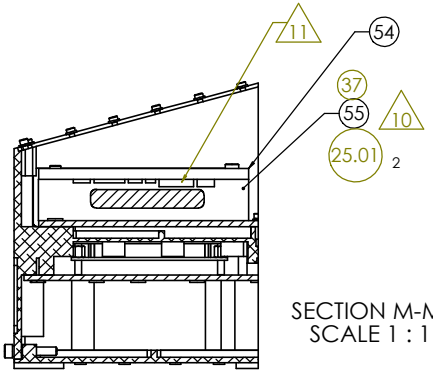

SECTION M-M
SCALE 1 : 1

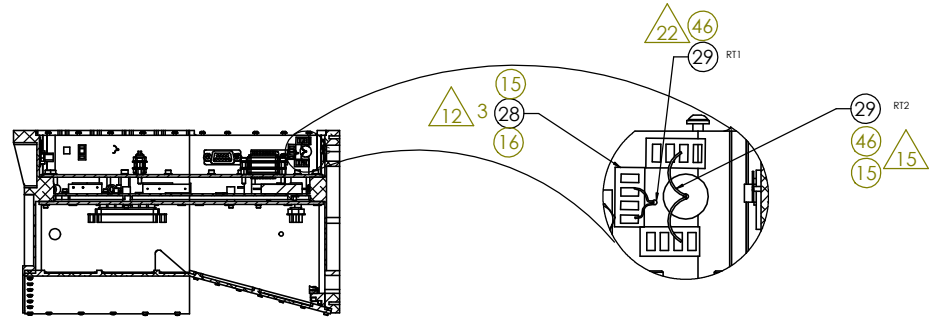

SECTION F-F

DETAIL G
SCALE 2 : 1

MIT/BU, CRATER PROJECT		
TITLE: ELECTRONICS ASSEMBLY, CRATER		
SIZE	DWG. NO.	REV
D	32-10200	A
SCALE: 1:2	WEIGHT:	SHEET 3 OF 3