

Connection to chassis ground made via mounting hardware.

Shield VINNEG and VINPOS, as well as all inputs and outputs of the EMI filter. Terminate shield to Chassis Ground.

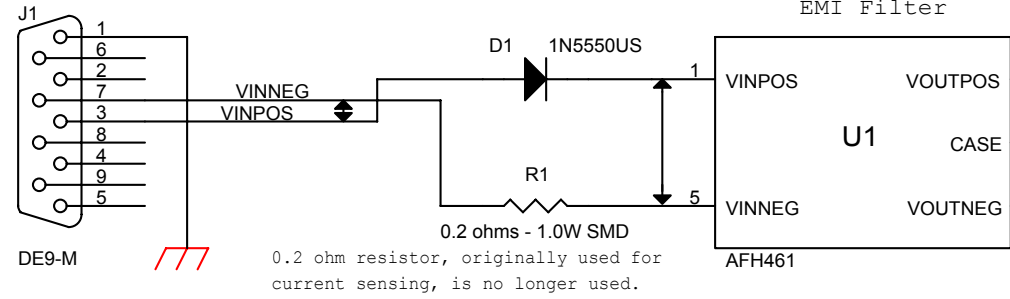

0.2 ohm resistor, originally used for current sensing, is no longer used.

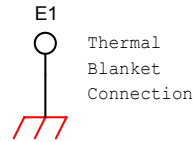
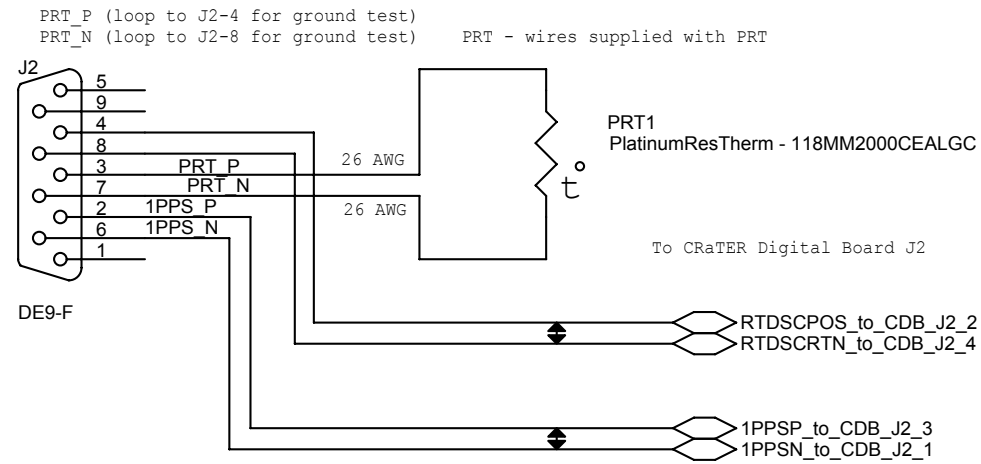

1553 Bus Connectors To CRaTER Digital Board J3

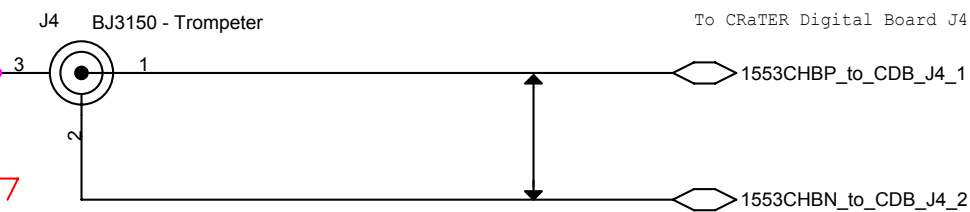
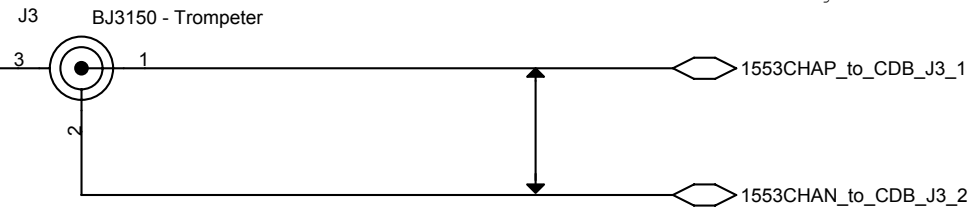

- Notes:
1. Unless otherwise noted, wire to be 22 AWG
 2. Legend:

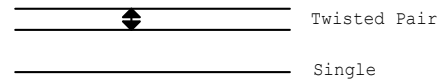

DC-DC Converters

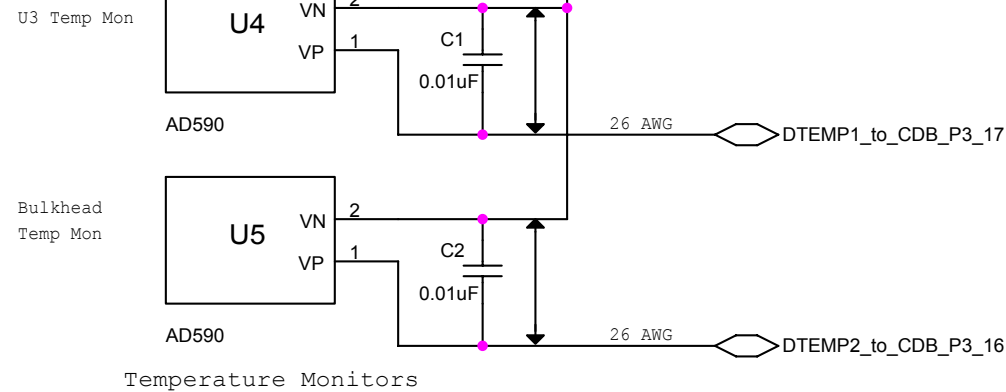
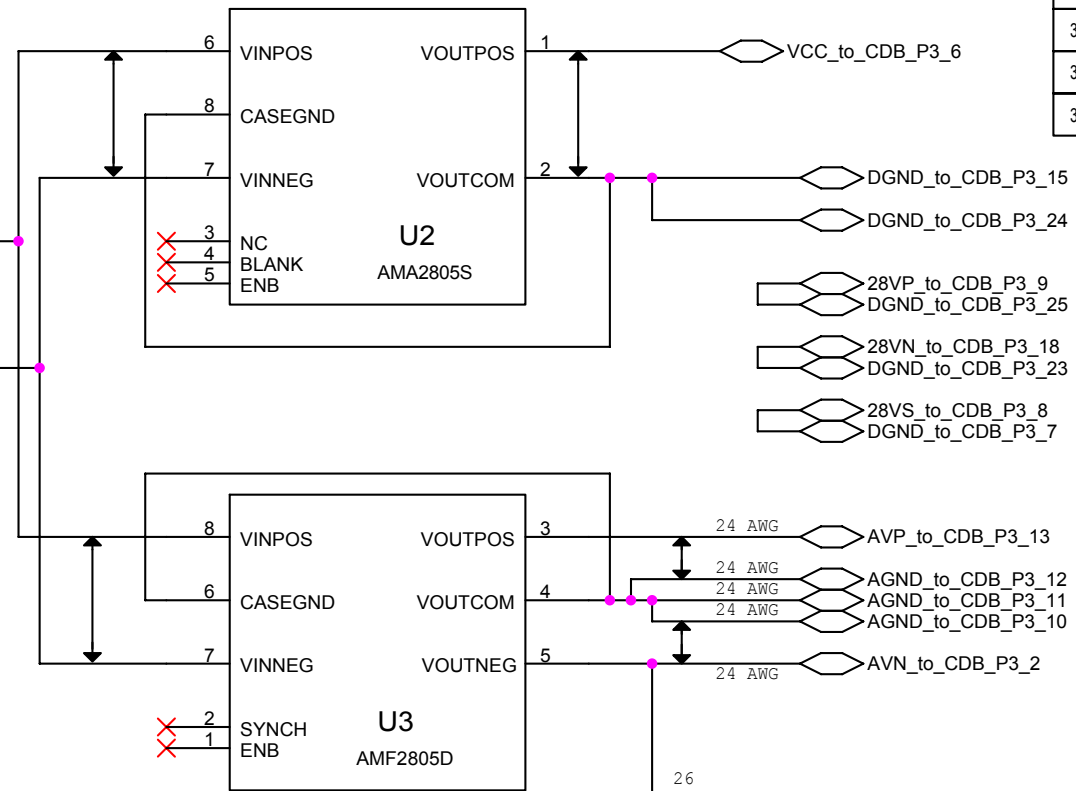

| ECO # | Rev | Description | Date | Approved |
|--------|-----|--------------------------------------------------------------------|----------|----------|
| 32- | A | Original Release | 08/30/06 | |
| 32-216 | B | Add C1, C2 and R2, misc clarifications | 05/04/07 | |
| 32-237 | C | Remove Purge Flow Rate Thermistors (RT1 and RT2) | 05/04/07 | |
| 32-253 | D | Remove 28V Sense Wires from harness; ground inputs at P3 Connector | 10/25/07 | |

Connection of 28VP, 28VN and 28VS to DGND (via jumpers directly on the P3 Connector) provides termination for Housekeeping Inputs.

P3 Spares

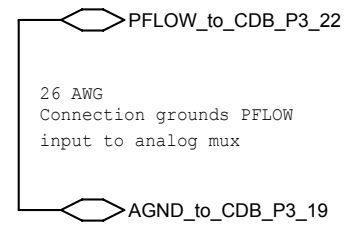
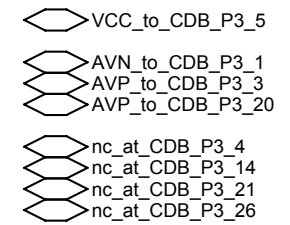

| | | |
|-----------------------------------------|----------------------------|--------------|
| Title | | |
| CRaTER, E-Box Chassis Wiring, Schematic | | |
| Size | Document Number | Rev |
| B | 32-03006 | D |
| Date: | Thursday, October 25, 2007 | Sheet 1 of 1 |