

REVISIONS					
REV.	ECO NO.	DESCRIPTION	CHECKED	APPROVED	DATE
A	36-540	INITIAL RELEASE			

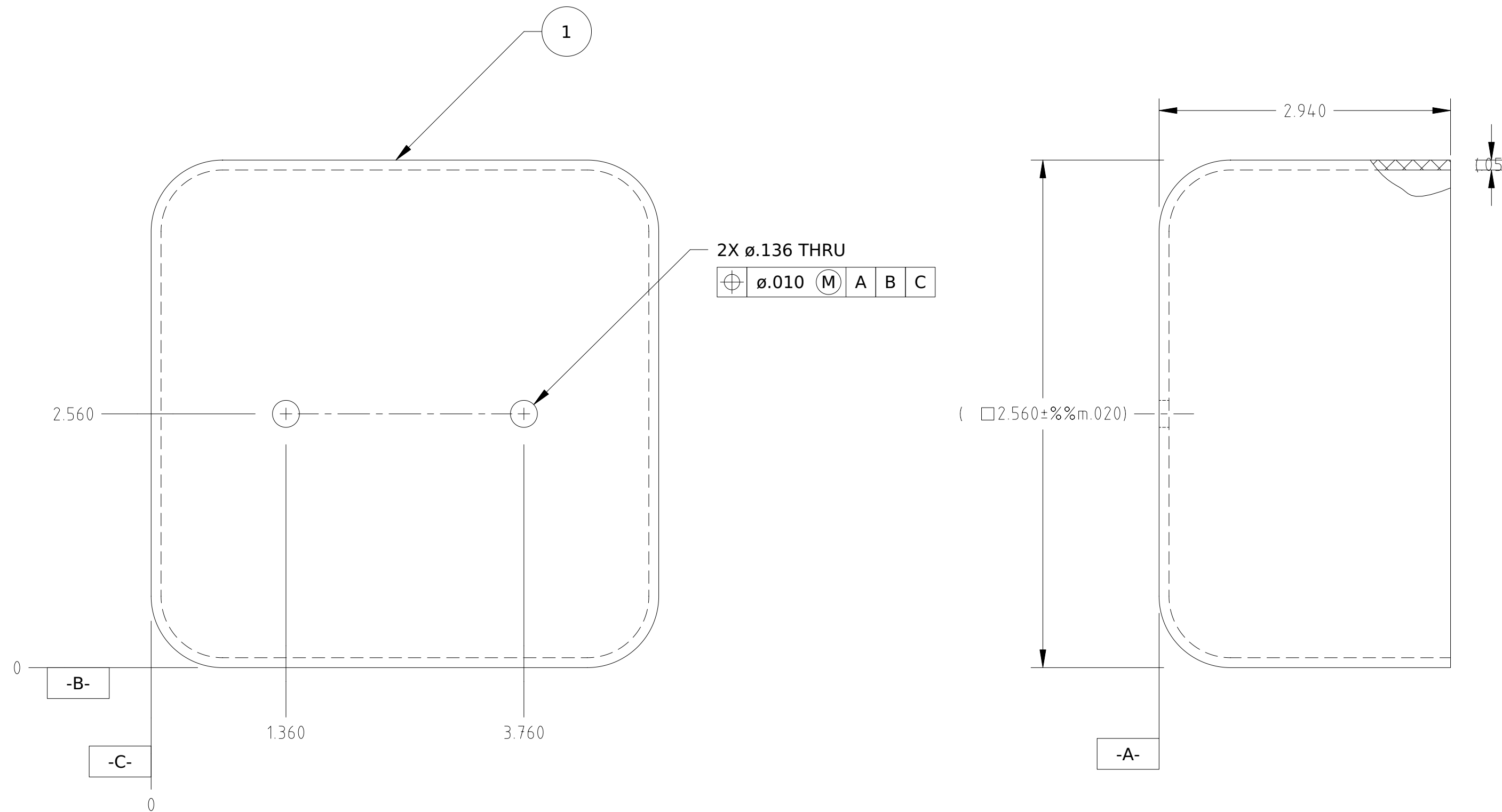

NOTES:

1. BREAK SHARP EDGES .01 RADIUS.
2. CONVERSION COAT PER MIL-C-5541, CLASS 3.

ALTERED ITEM DRAWING

		UNLESS OTHERWISE SPECIFIED DIMENSIONS ARE IN INCHES TOLERANCE: ANGLES ± 1° 3 PLACE DECIMALS ± .005 2 PLACE DECIMALS ± .01	NAME	DATE	MASSACHUSETTS INSTITUTE OF TECHNOLOGY CENTER FOR SPACE RESEARCH CAMBRIDGE, MA 02139			
			DRAWN	J. COOK	9/9/94	EXTERNAL CALIBRATION SOURCE COVER		
		MATERIAL	CHECKED		SIZE			
36-40200	ACIS	SEE DATABASE	APPROVED		C	80230	36-40207	A
NEXT ASSEMBLY	USED ON	INTERPRET DIMENSIONS AND TOLERANCES IAW ANSI Y14.5M-1982	RELEASED		SCALE:	1/1	SHEET	1 OF 1
APPLICATION			WEIGHT					