

REVISIONS					
REV.	ECO NO.	DESCRIPTION	CHECKED	APPROVED	DATE
A	36-351	INITIAL RELEASE			

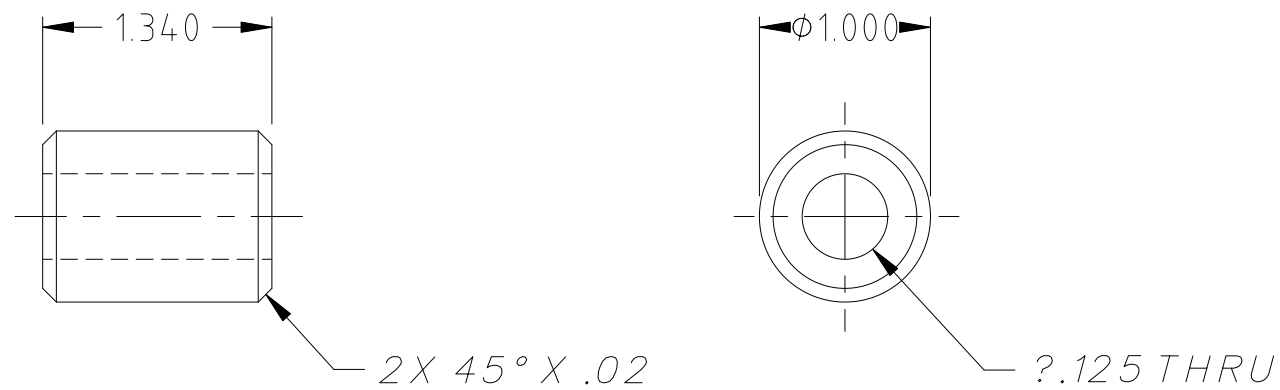

NOTES:

1. REMOVE ALL BURRS AND SHARP EDGES R .010.
2. FINISH: CHEMICAL CONVERSION COAT PER MIL-C-5541, CLASS 3.
3. HANDLE WITH CONTAMINATION FREE, POWDER FREE GLOVES DURING ALL POST-FINISH OPERATIONS.
4. BAG AND TAG WITH PART NUMBER AND REVISION.

		UNLESS OTHERWISE SPECIFIED DIMENSIONS ARE IN INCHES TOLERANCE: ANGLES ? 1° 3 PLACE DECIMALS ? .005 2 PLACE DECIMALS ? .01	NAME	DATE	MASSACHUSETTS INSTITUTE OF TECHNOLOGY CENTER FOR SPACE RESEARCH CAMBRIDGE, MA 02139				
			DRAWN	M.LYONS	13MAY96	SPACER			
			CHECKED						
		MATERIAL ALUMINUM 6061-T6	APPROVED		SIZE		CAGE CODE	DWG. NO.	REV.
36-30202	ACIS		RELEASED		B	80230	36-30202.17	A	
NEXT ASSEMBLY	USED ON		WEIGHT		SCALE 4:1		SHEET 1 OF 1		
APPLICATION									