

REVISIONS					
REV.	ECO NO.	DESCRIPTION	CHECKED	APPROVED	DATE
A	36-379	INITIAL RELEASE	FJK	RFG	11/6/95
B	36-674	ADD HANDLING NOTES			

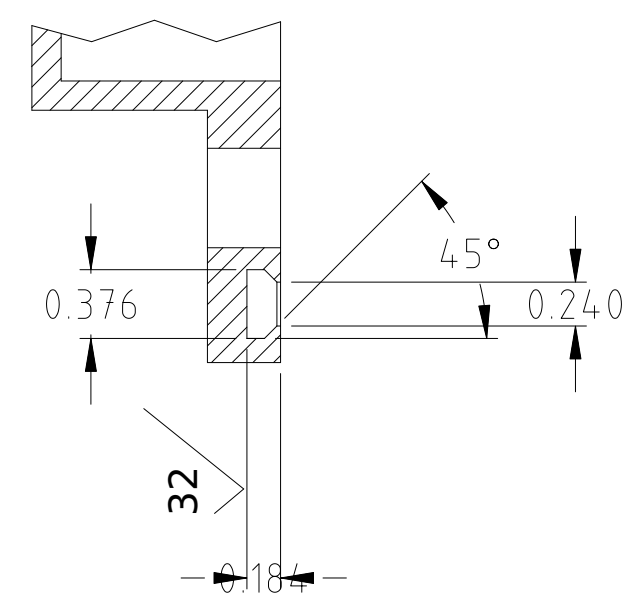
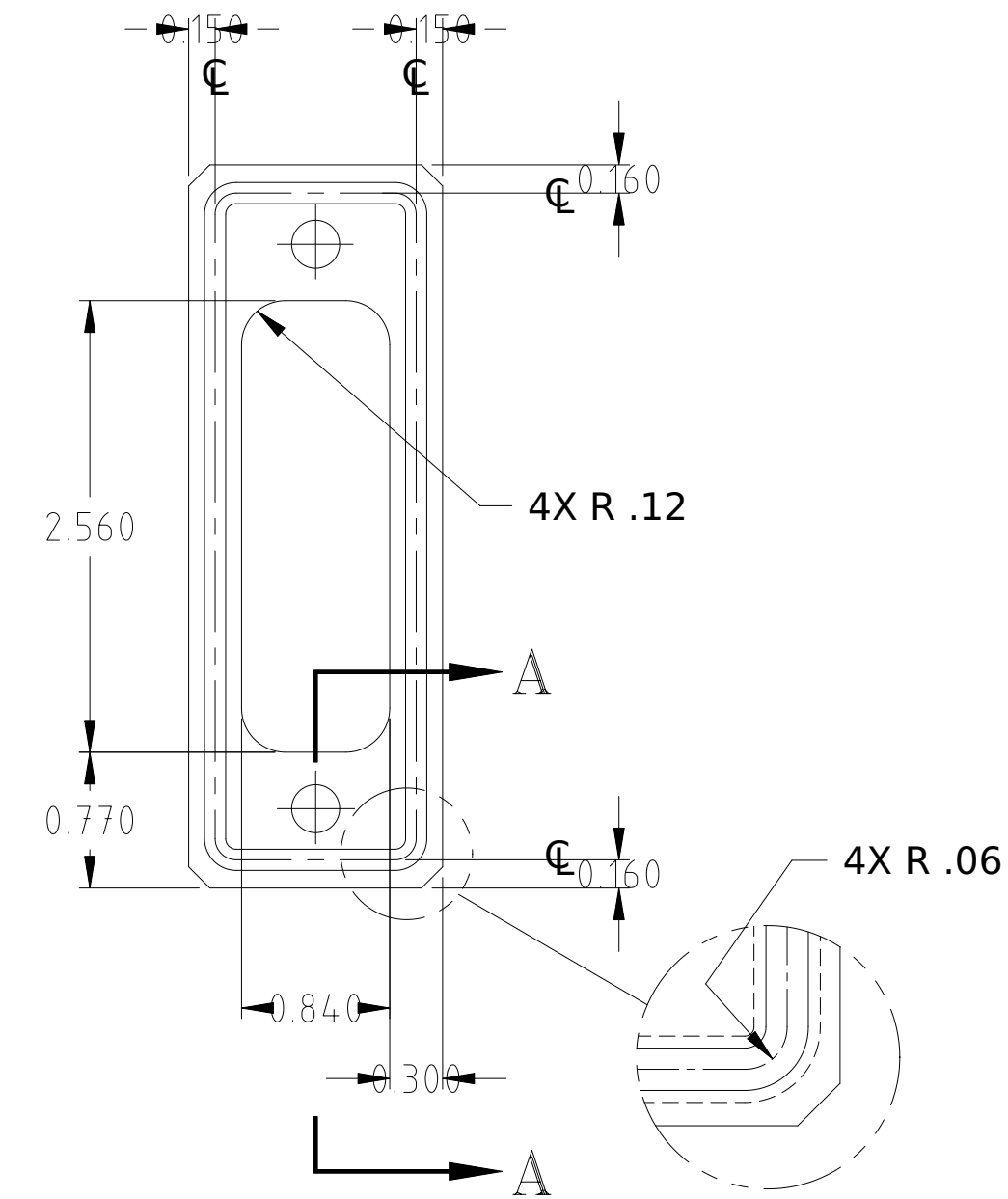
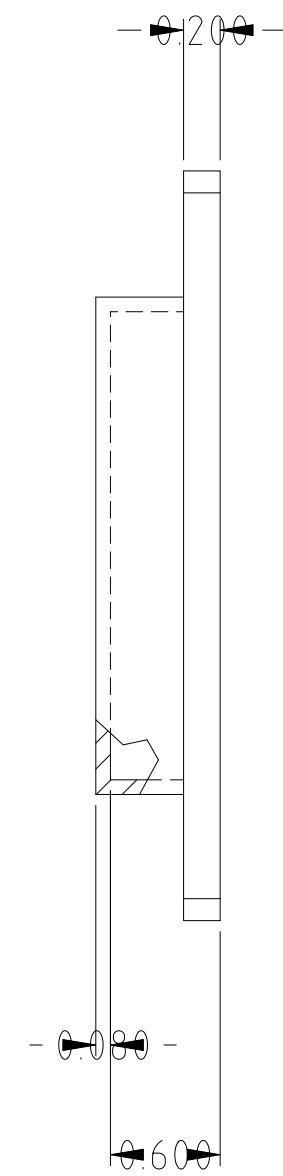
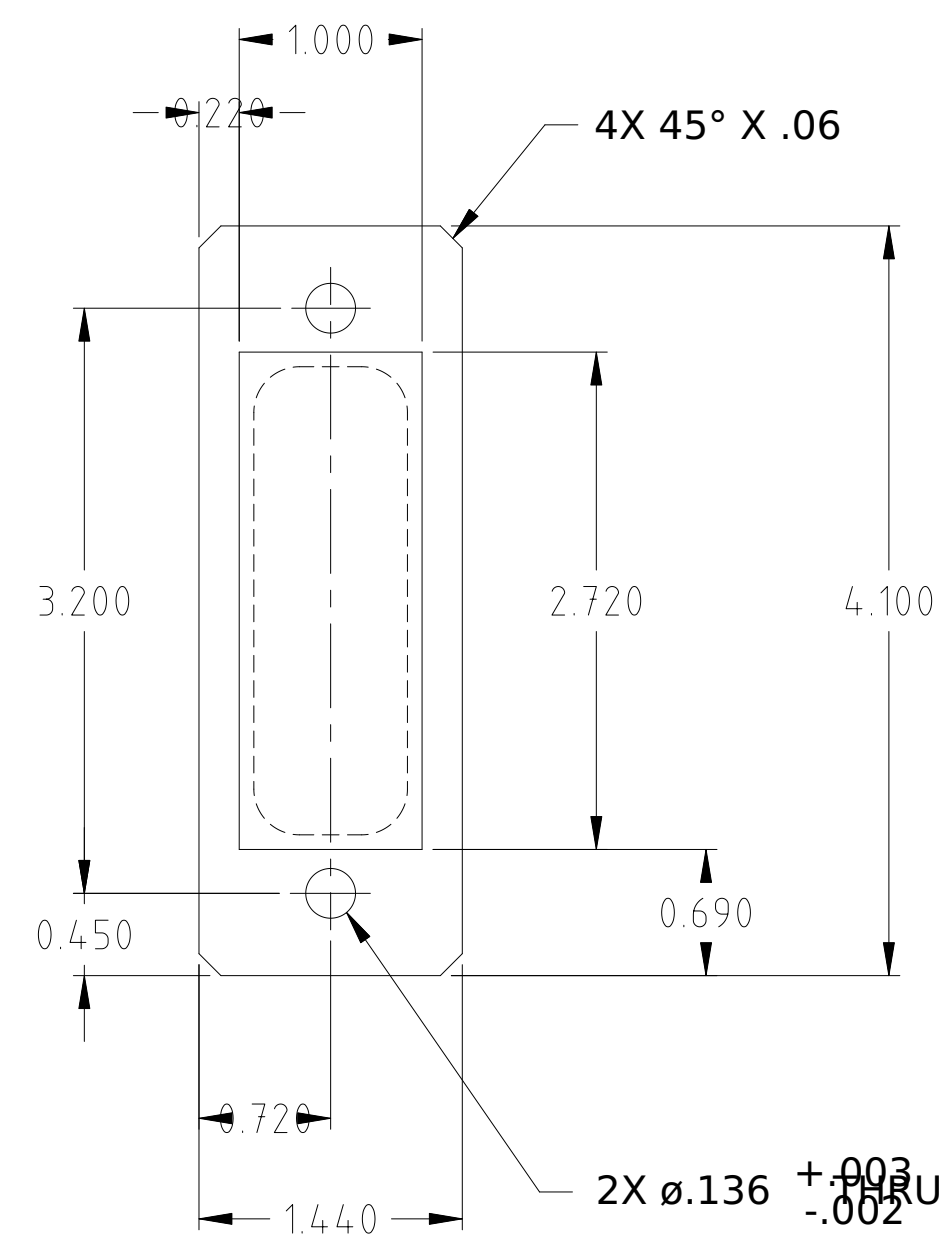

SECTION A-A
SCALE: 4/1

NOTES:

- REMOVE BURRS AND SHARP EDGES R .010 OR CHAMFER MAX.
- SUGGESTED DOVETAIL GROOVE CUTTING TOOL: SPIRA P/N GC-1-04b.
MANUFACTURER SUGGESTS MILLING .046 $\pm .002$ WITH $\pm .000$
STANDARD TOOL FIRST, THEN FINISH WITH DOVETAIL CUTTING TOOL.
SPIRA MANUFACTURING CORP.
12721 SATICOY STREET SOUTH, UNIT B
NORTH HOLLYWOOD, CA 91605
(818) 764-8222
- FINISH: CHEMICAL CONVERSION COAT ALL OVER PER MIL-C-5541, CLASS 3.
MASK PART AS SHOWN. PAINT REMAINING SURFACES USING AEROGLAZE
9924 (PRIMER) AND Z306, BLACK (PAINT) IAW MIT SPECIFICATION 36-02028.
- BAG AND TAG WITH MIT DRAWING NUMBER AND LATEST REVISION.
- HANDLE ITEM WITH POWDER FREE, CONTAMINATION FREE GLOVES DURING ALL POST FINSH OPERATIONS.

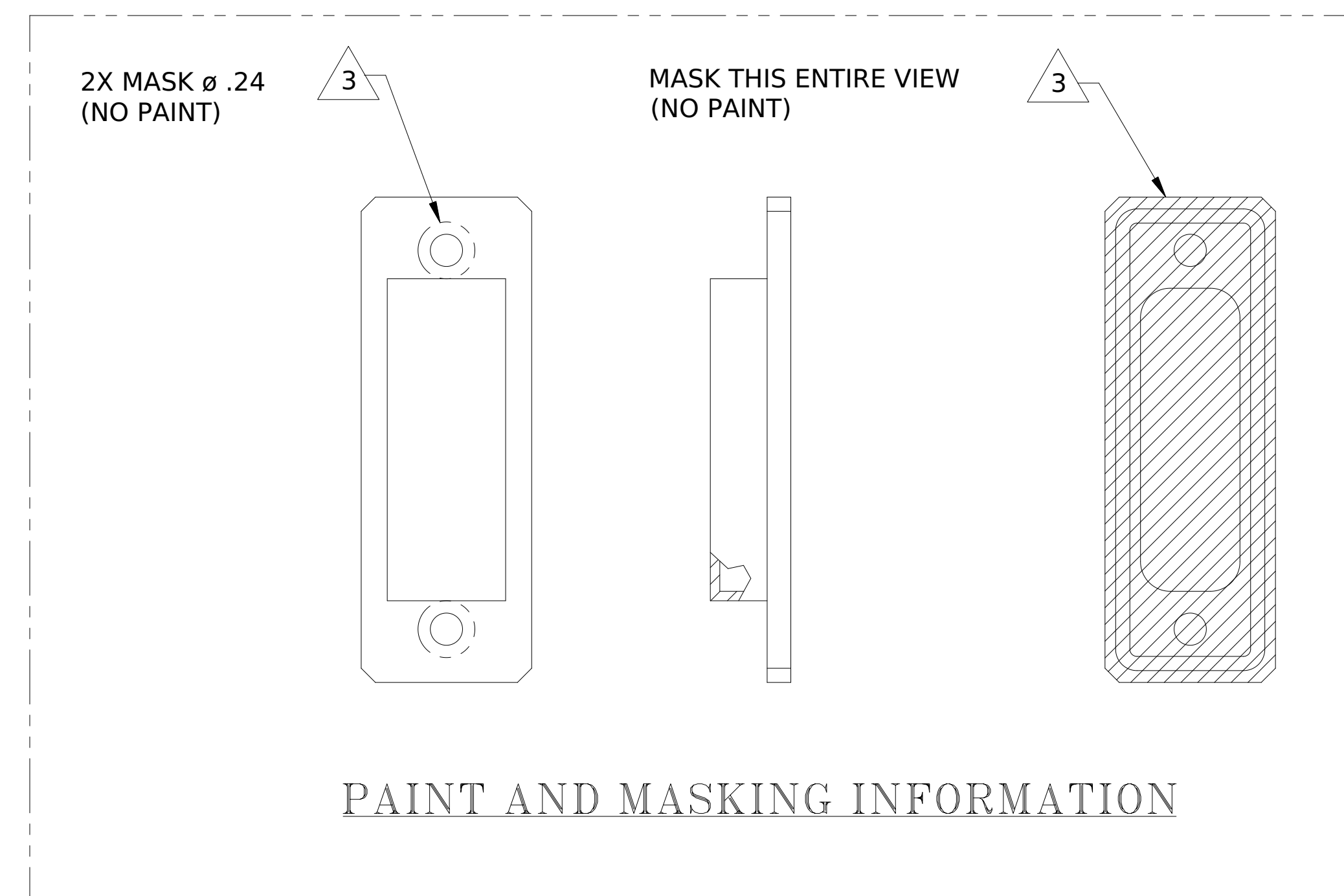

PAINT AND MASKING INFORMATION

36-30200		MATERIAL ALUMINUM 6061-T6		NAME M.LYONS		DATE 07MAY95		MASSACHUSETTS INSTITUTE OF TECHNOLOGY CENTER FOR SPACE RESEARCH CAMBRIDGE, MA 02139	
36-20200		ACIS		CHECKED F. Kasparian		11/6/96			
NEXT ASSEMBLY		USED ON		APPROVED R. Goetze		11/6/96		COVER, CONNECTOR, +Y	
APPLICATION		INTERPRET DIMENSIONS AND TOLERANCES IAW ANSI Y14.5M-1982		RELEASED D. Gage		11/6/96			
				WEIGHT		SCALE 2:1		SHEET 1 OF 1	
				SIZE D		CAGE CODE 80230		DWG. NO. 36-20219	
								REV. B	