

REVISIONS					
REV.	ECO NO.	DESCRIPTION	CHECKED	APPROVED	DATE
A	30-025	INITIAL RELEASE (from 30-10400_r06)	EAB	RICK F	11/02
B	30-034	ADD RELIEF CUT FOR ADHESIVE			
C	30-039	ADD RELIEF CUT FOR NEW COLLARS			

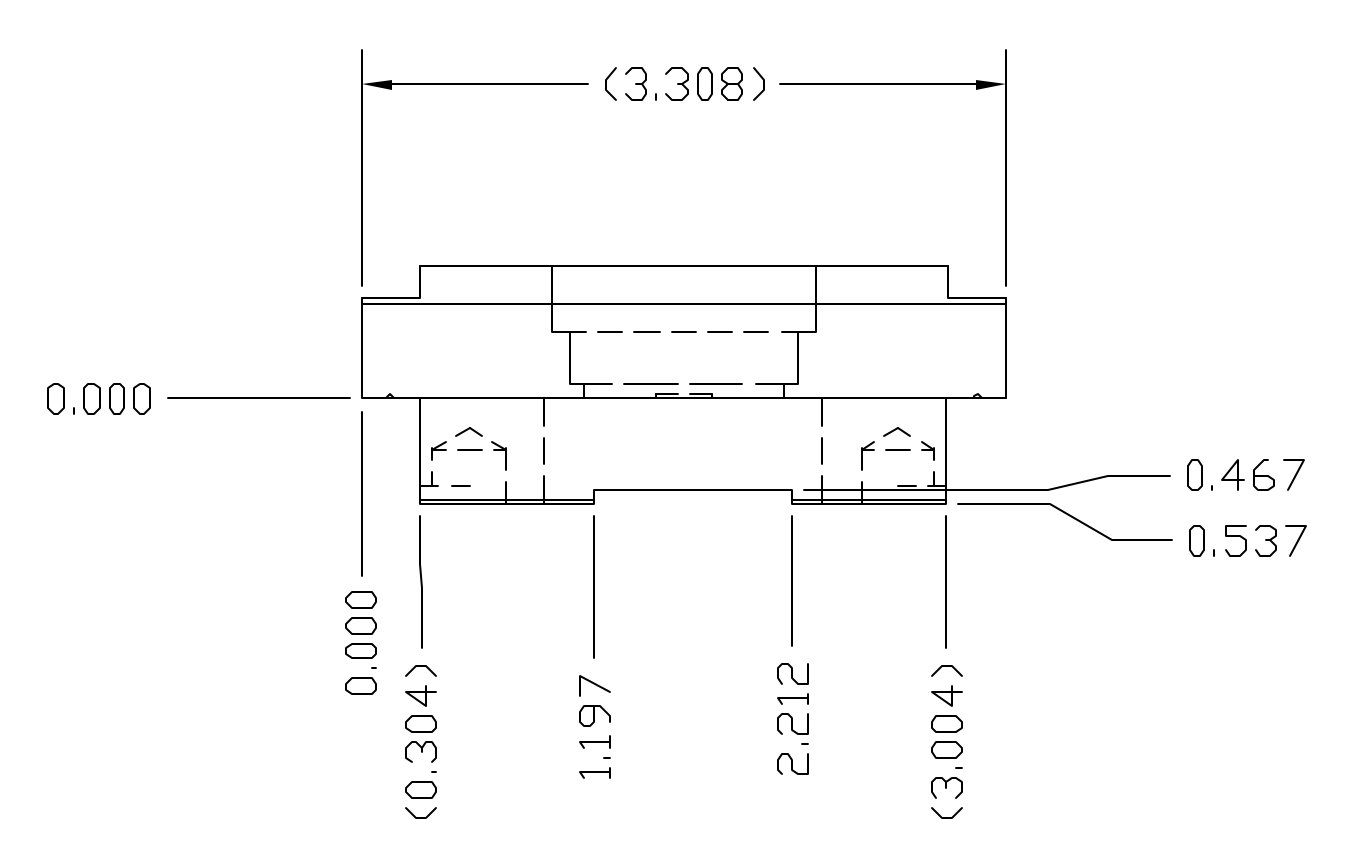
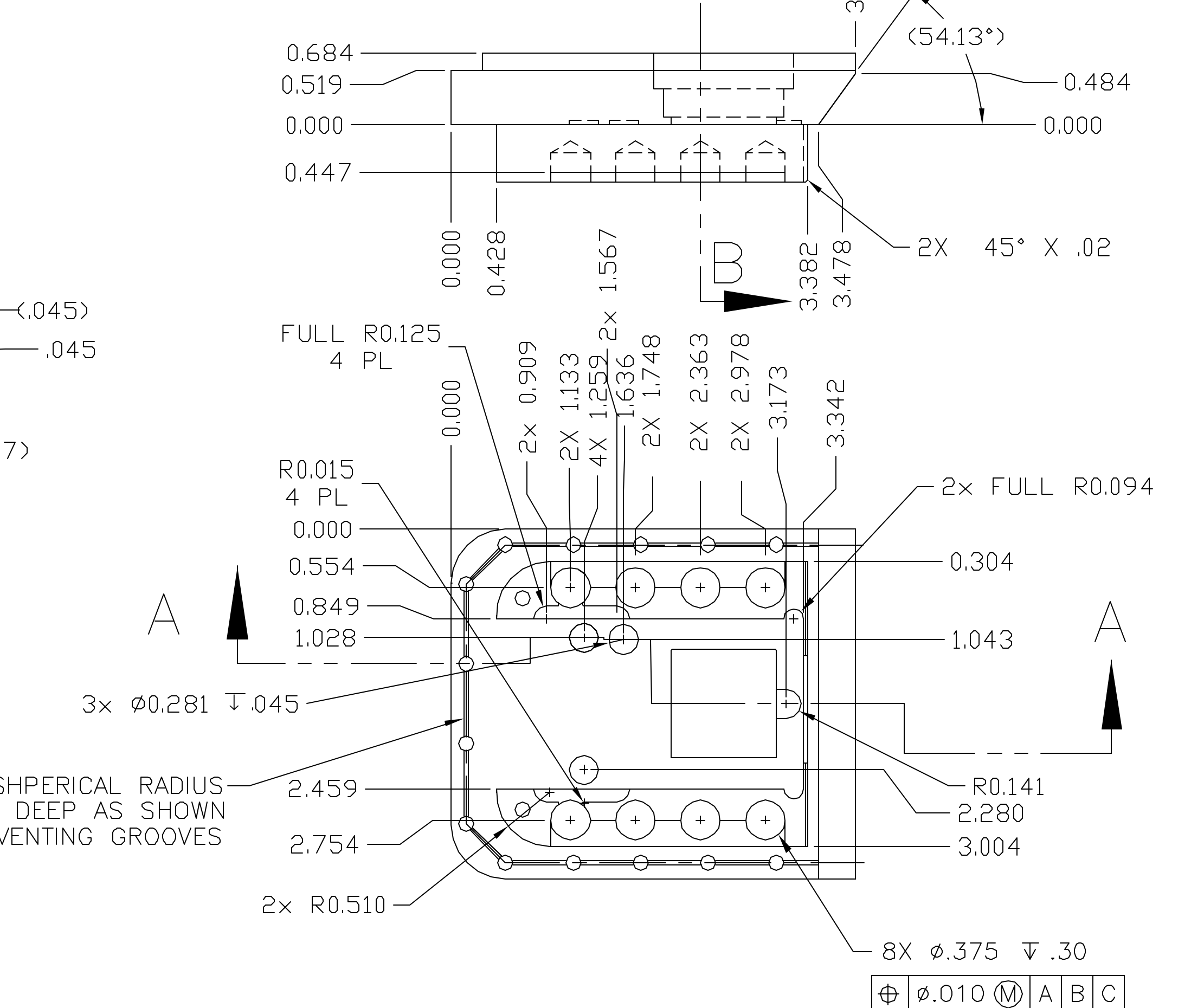
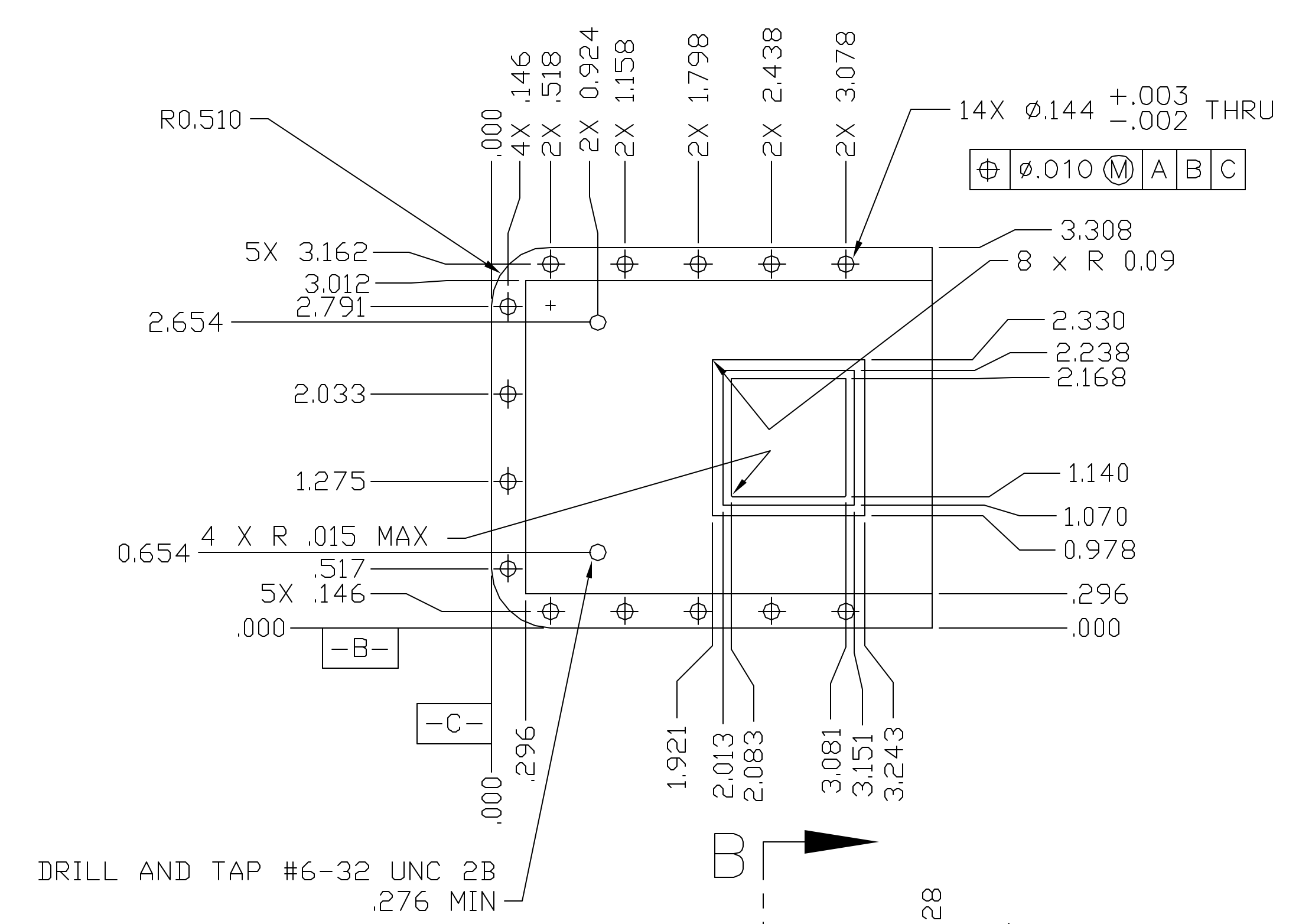
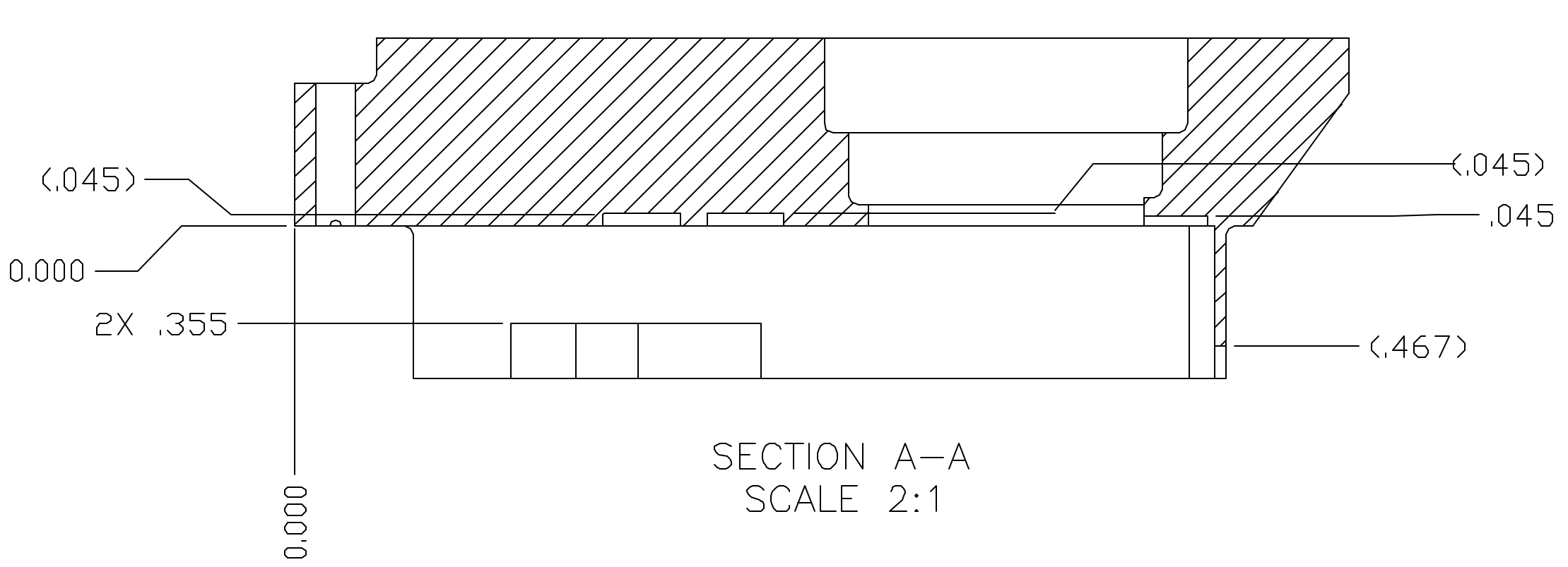
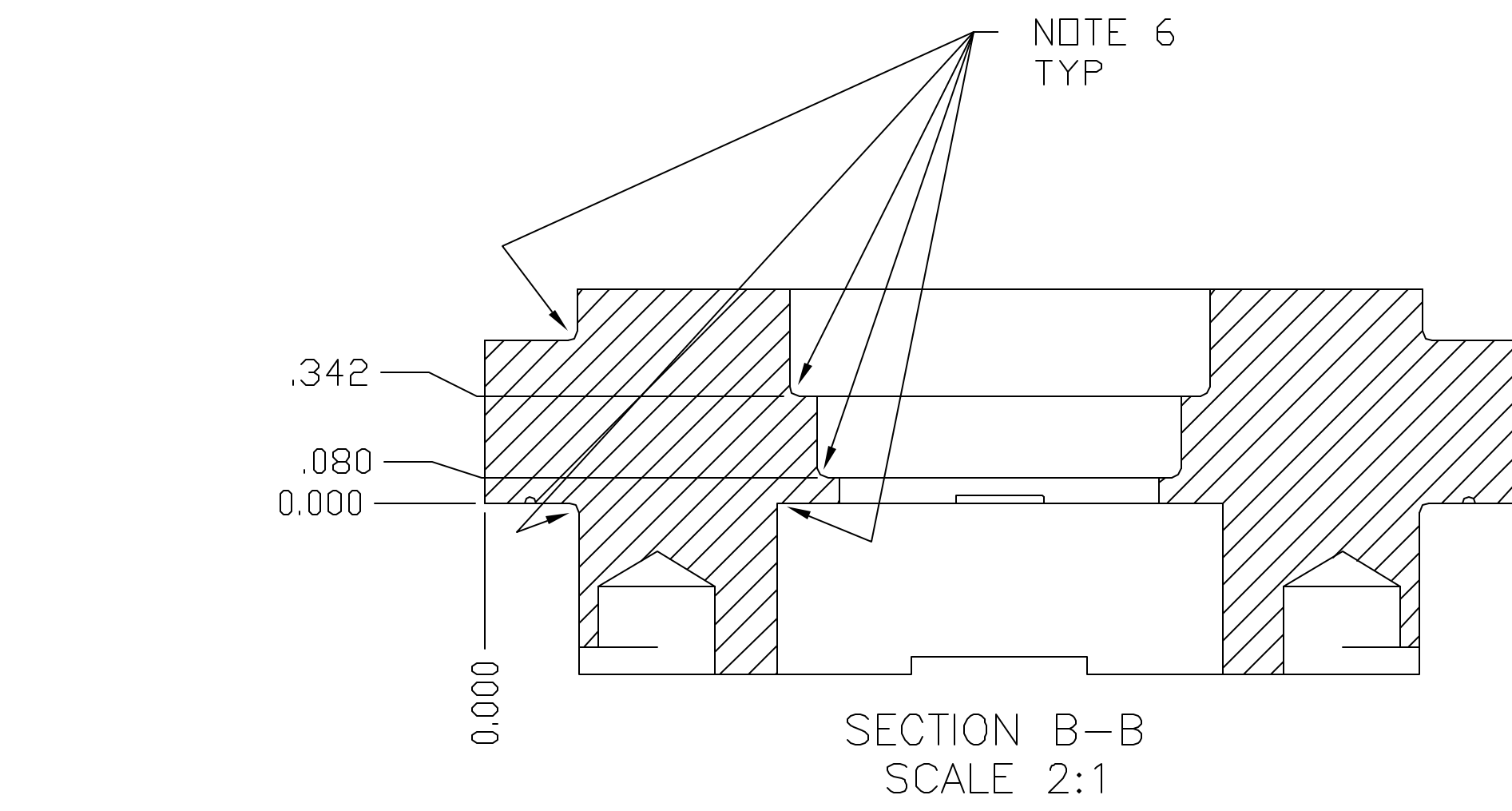

- NOTES:
1. MATERIAL: ALUMINUM ALLOY 6061-T651 PER QQ-A-250/11.
  2. REMOVE ALL BURRS AND SHARP EDGES R.005-.010 .
  3. UNTOLERANCED DIMENSIONS LOCATING TRUE POSITION ARE BASIC.
  4. PLATING : ELECTROLESS NICKEL PLATE PER ASTM B 733-90, SC1, TYPE-I, CLASS 4, AlMg1Si0.6/NiP 5, 200 ±50 MICRO INCHES THICK. MINIMUM PHOSPHORUS CONTENT OF THE NICKEL DEPOSIT SHALL BE 8%. OVERPLATE GOLD PER MIL-G-45204 TYPE-III, GRADE A, 25-50 MICRO INCHES THICK.
  5. CLEAN AND HANDLE IN ACCORDANCE WITH 30-01303.
  6. ALL FILLETS TO BE RADIUS .005-.010.

15X .02 SPHERICAL RADIUS  
.02 DEEP AS SHOWN  
VENTING GROOVES

UNLESS OTHERWISE SPECIFIED:  
DIMENSIONS SHALL BE INTERPRETED IAW ANSI Y14.5 - 1982  
DIMENSIONS ARE IN INCHES  
TOLERANCE: ANGLES ±1°  
3 PLACE DECIMALS ±.005  
2 PLACE DECIMALS ±.01  
THIRD ANGLE PROJECTION

MASSACHUSETTS INSTITUTE OF TECHNOLOGY CENTER FOR SPACE RESEARCH CAMBRIDGE, MA 02139	
COVER, SHIELDING	
SIZE CAGE CODE D 80230	DWG. NO. 30-10400
SCALE 1:1	REV. C SHEET 1 OF 1

NAME	DATE
DRAWN M. SMITH	11/8/02
CHECKED EAB	11/14/02
APPROVED R. FOSTER	11/23/02
RELEASED D. GAGE	11/23/02
WEIGHT	