

REV.		ECD NO.	DESCRIPTION	REVISIONS		
CHECKED	APPROVED	DATE				
A	30-008	INITIAL RELEASE (from 29-10201_rA)				

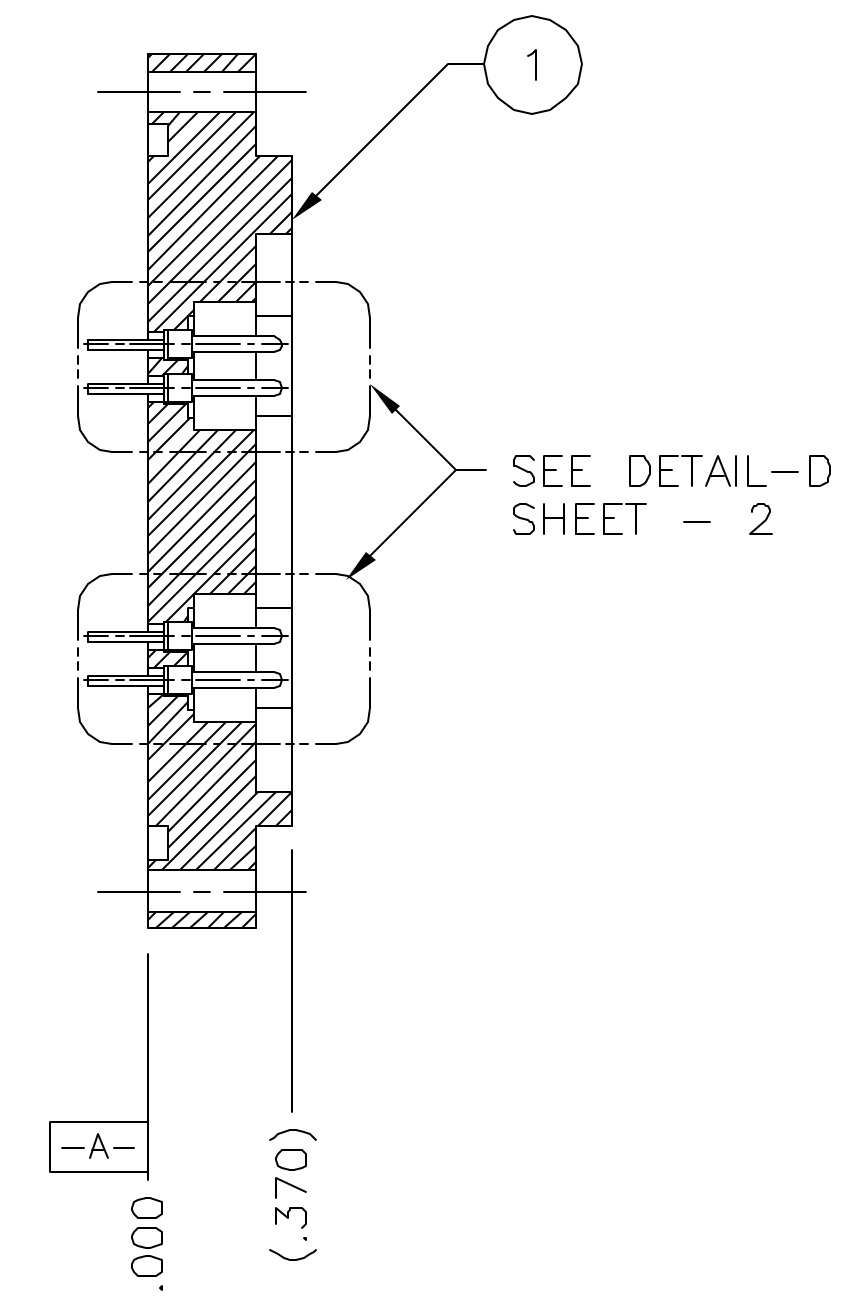

SECTION A-A

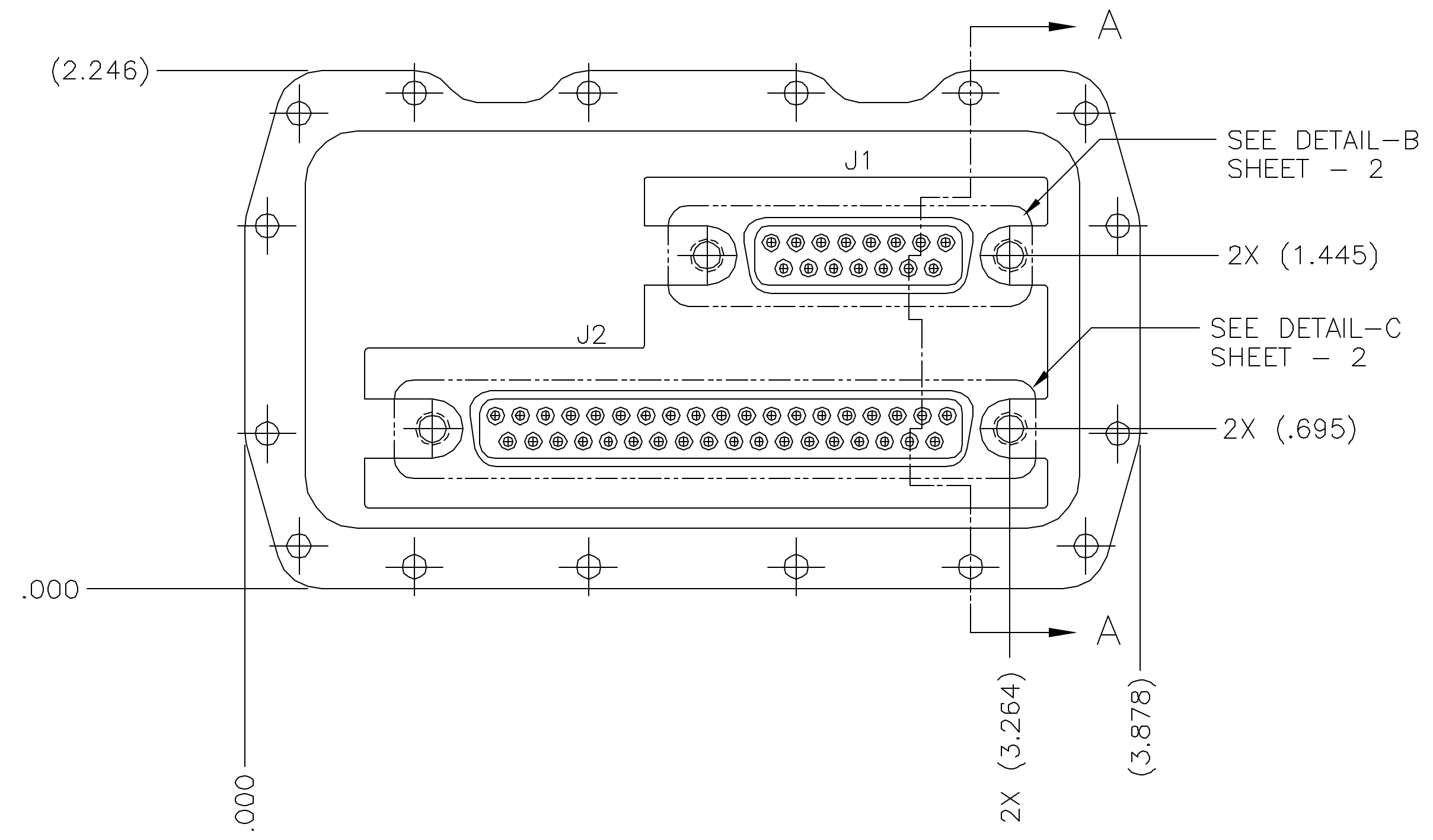
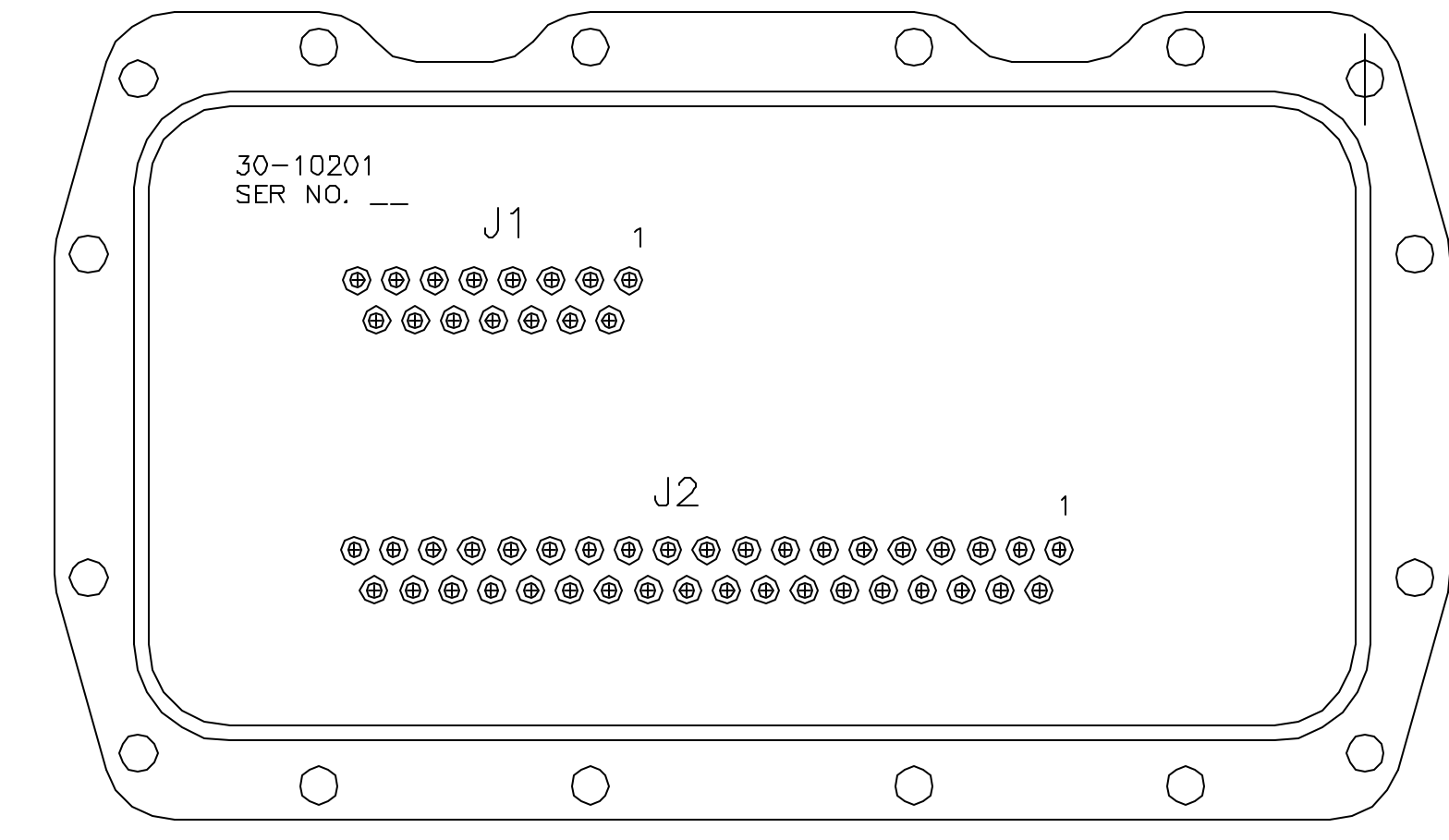

NOTES:

- 1. SOURCE: SPECIAL HERMETIC PRODUCTS, INC.
P.O. BOX 269, RIVERVIEW MILL,
WILTON, NH 03086
PHONE NO. (603) 654-2002
- 2. SOLDER: SN96
- 3. MAXIMUM HELIUM LEAK RATE FOR ENTIRE ASSEMBLY:
 1×10^{-7} STANDARD CC/SEC AT 1 ATM PRESSURE DIFFERENTIAL.
- 4. UNTOLERANCED DIMENSIONS LOCATING TRUE POSITION ARE BASIC.
- 5. NOT USED
- 6. HANDLE IN ACCORDANCE WITH 30-01303.

UNLESS OTHERWISE SPECIFIED:		MASSACHUSETTS INSTITUTE OF TECHNOLOGY CENTER FOR SPACE RESEARCH CAMBRIDGE, MA 02139	
DIMENSIONS SHALL BE INTERPRETED IAW ANSI Y14.5 - 1982		CONNECTOR PLATE	
DIMENSIONS ARE IN INCHES TOLERANCE: ANGLES $\pm 1^\circ$ 3 PLACE DECIMALS $\pm .005$ 2 PLACE DECIMALS $\pm .01$			
THIRD ANGLE PROJECTION		SIZE CAGE CODE D 80230	DWG. NO. 30-10201
DRAWN		REV. A	
CHECKED		SHEET 1 OF 2	
APPROVED			
RELEASED			
WEIGHT NOT DETERMINED			

